

SN-W Model Disc

**PARTS
&
Operator
Manual**

**SUPER NARROW
WHEEL
VINEYARD DISC
3'8" TO 7'6"**

Domries Enterprises, Inc.

12281 Road 29

Madera, Ca 93638

Phone (559) 673-9143 Fax (559) 673-4110

Visit our web-site at <http://www.domriesentinc.com>

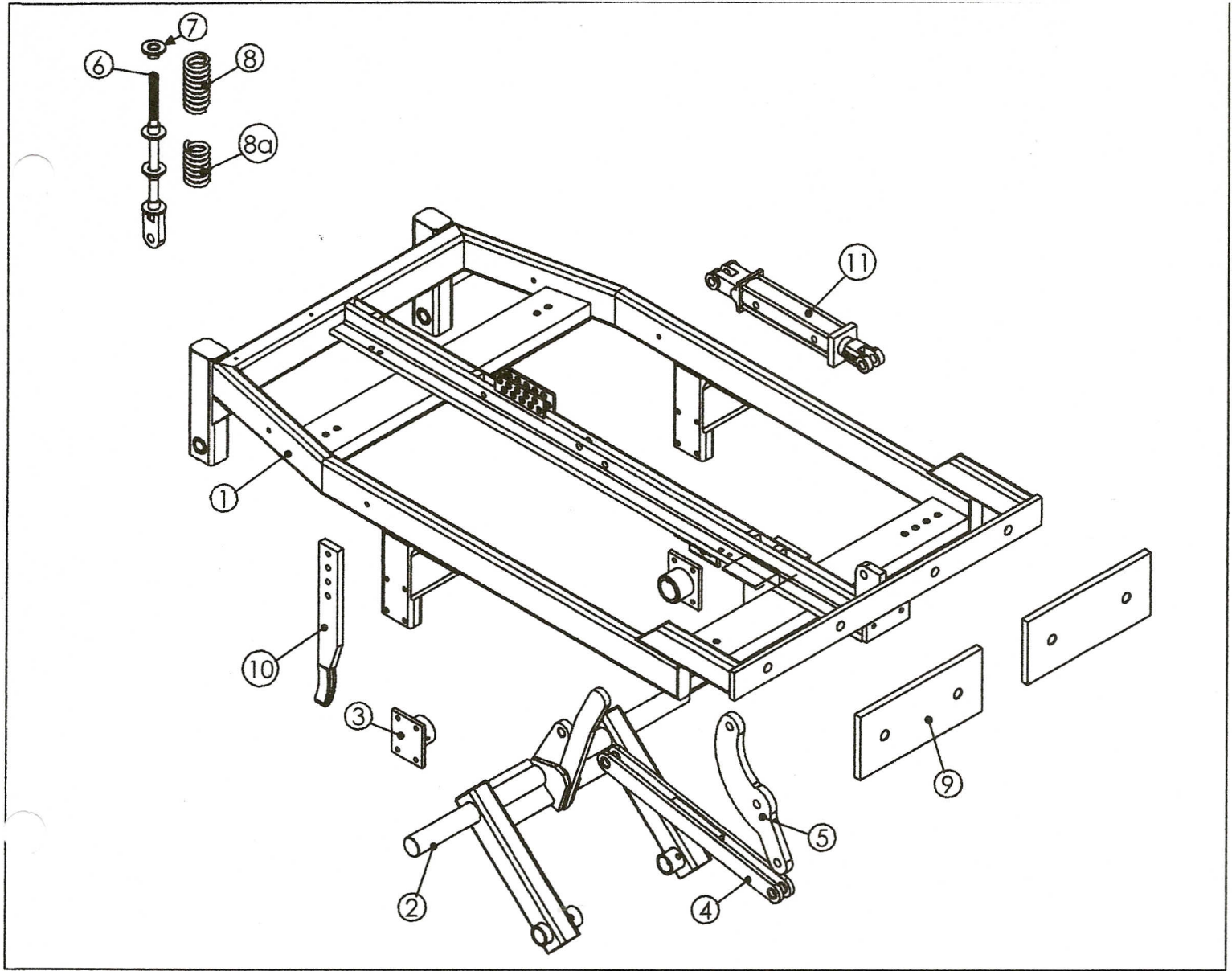

SN-W MAIN FRAME

REF #	PART #	DESCRIPTION	WT./LB.
1	SN-W-01	MAIN FRAME WHEEL DISC	800.0 LBS.
2	SN-W-02	AXLE WELDMENT	189.0 LBS.
3	SN-W-05	AXLE BLOCKS	4.5 LBS.
4	SN-W-24	LINK - AXLE	20.0 LBS.
5	SN-W-23	LINK - ARM, "S" SHAPE (HOOKS TO HYD. CLY.)	N/A
6	SN-W-07	LEVELING ROD FRONT	13.5 LBS.
7	W1125	COLLAR SPING	0.3 LBS.
8	SN-W-10-L	SPRING LEVELING - UPPER	3.0 LBS.
8a	SN-W-10-S	SPRING LEVELING - LOWER	2.5 LBS.
9	SN-W-29	WIEIGHT	50.0 LBS.
10	SN-W-33	CENTER SHANK	17.0 LBS.
11	HWO-310C	HYD. CYLINDER - 3" X 10" STROKE	26.0 LBS.

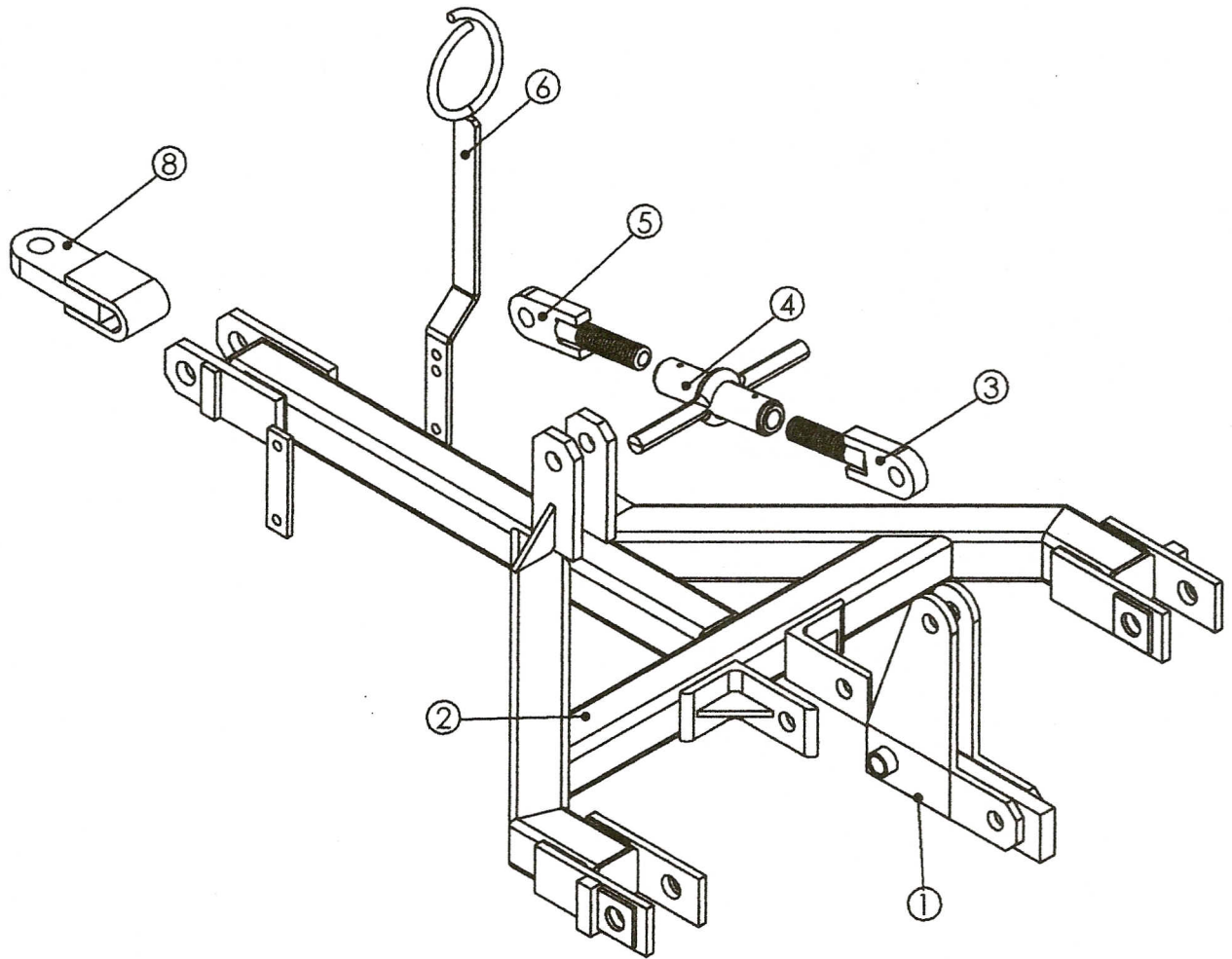

HITCH ASSEMBLY

REF #	PART #	DESCRIPTION	WT./LB.
1	SN-W-04	LINK CONTROL	37.2 LBS.
2	SN-W-03	HITCH	95.0 LBS.
3	OH-143	ROD - TURNBUCKLE , R.H. THRD.	4.2 LBS.
4	OH-142	BODY - TURNBUCKLE	5.6 LBS.
5	OH-140	ROD - TURNBUCKLE , L.H. THRD.	4.2 LBS.
6	OH-136	HOSE GUID & CLAMP	4.2 LBS.
7	OL-135	TONGUE - SINGLE LIP	11.0 LBS.

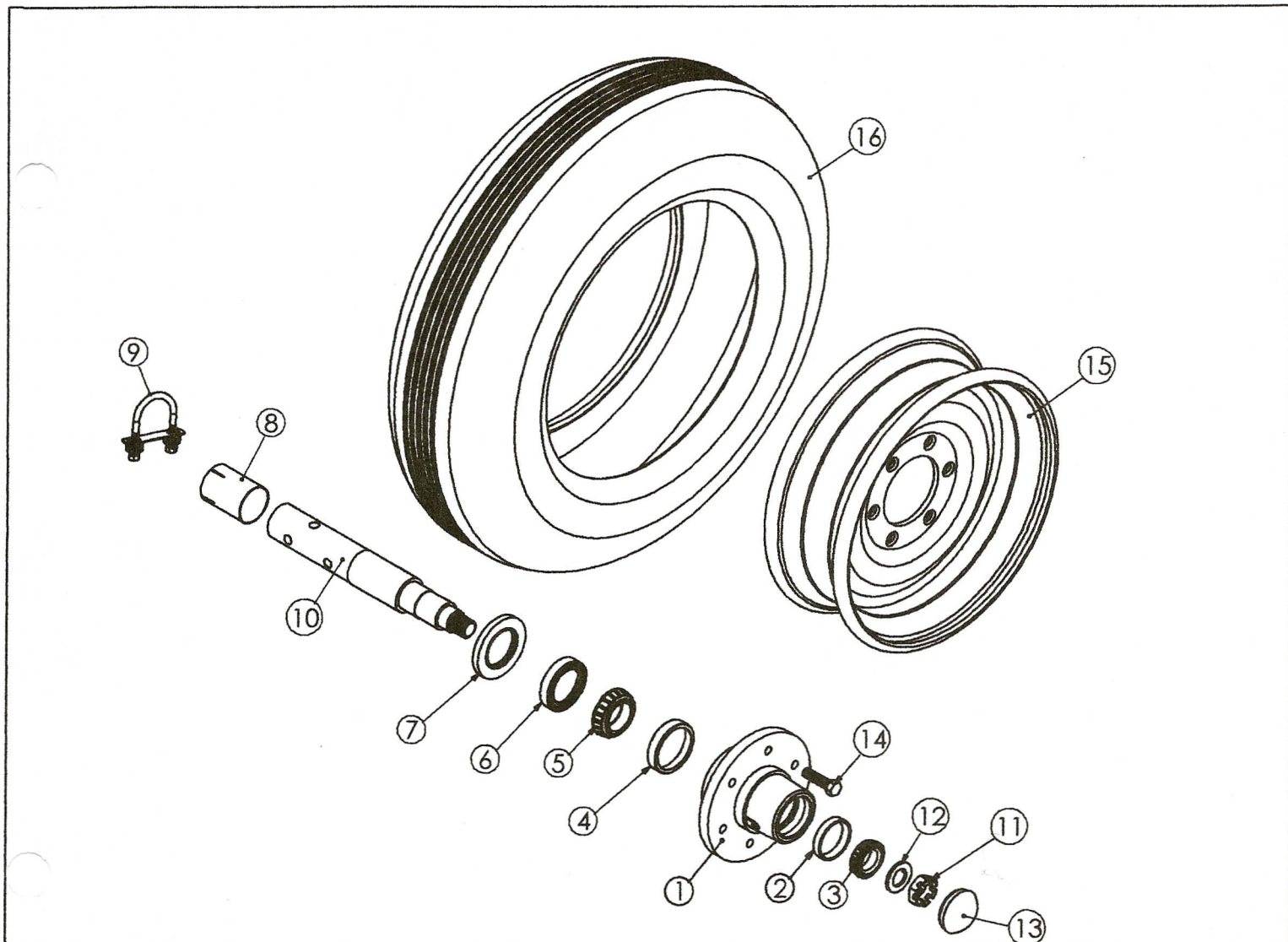

SN-W SPINDLE ASSEMBLY

REF #	PART #	DESCRIPTION	WT./LB.
1	DSH-302	HUB	10-0 LBS.
2	DSH-303	BEARING CUP, OUTER	0.1 LBS.
3	DSH-304	BEARING CONE, OUTER	0.3 LBS.
4	DSH-305	BEARING CUP, INNER	0.2 LBS.
5	DSH-306	BEARING CONE, INNER	0.4 LBS.
6	DSH-307	INNER SEAL	0.1 LBS.
7	DSH-308	OUTER SEAL	0.1 LBS.
8	DSH-309	TUBING SLEEVE	0.3 LBS.
9	DSH-310	CLAMP ASSY.	0.31 LBS.
10	DSH-312-S	SLIP IN SPINDLE	9.0 LBS.
11	DSH-313	SLOTTED NUT	0.1 LBS.
12	DSH-314	SPINDLE WASHER	0.01 LBS.
13	DSH-316	DUST CAP	0.2 LBS.
14	DSH-318	LUG BOLT - (1/2" NF X 1" LG.)	0.1 LBS.
15	SN-W-09	WHEEL 12 X 5, 6 (1/2)	12.5 LBS.
16	SN-W-08-6	TIRE 23 X 8.8 - 12	16.0 LBS.

SN-02-W

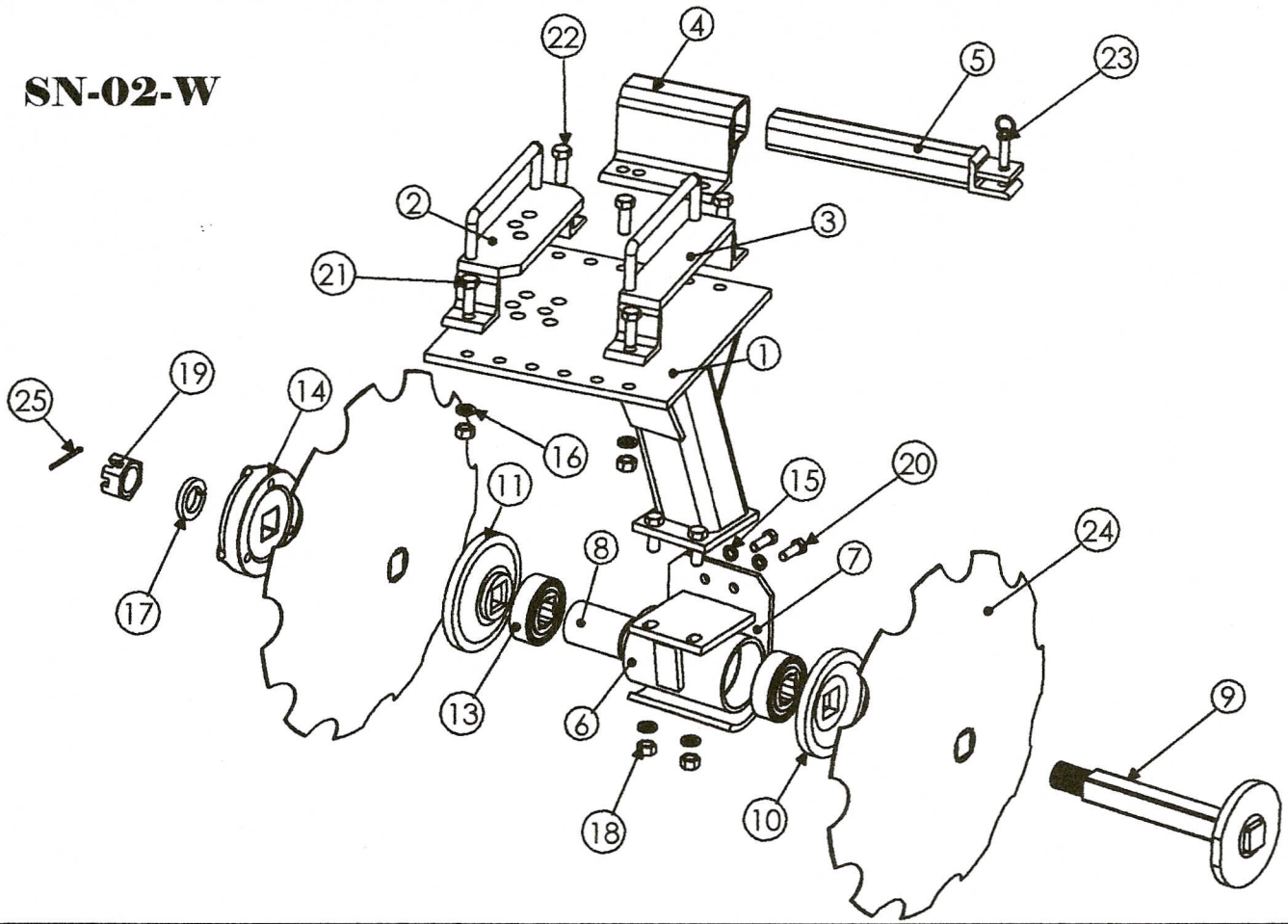

2 BLADED, LEFT FRONT, 9" SPACING

REF #	PART #	GANG FRAME ASSEMBLY	WT./LB.
1	SN-02-W	GANG FRAME 1" PLATE	85.3 LBS.
2	SN-06	YOKE PIVOT	10.3 LBS.
3	SN-08	YOKE HOLD DOWN	8.6 LBS.
4	SN-09-E	SET BAR HOLDER-EXTENDED	9.3 LBS.
5	SN-10	SET BAR FRONT	6.9 LBS.
6	SN-13	BEARING HOUSING	14.2 LBS.
7	SN-15	WEAR GUARD	14.2 LBS.
8	SN-21	BRG. INSERT	2.4 LBS.
9	SN-26	GANG ROD, 1 1/2" SQ.	12.6 LBS.
10	SN-29	HALF SPOOL-CVX, 1 1/2" SQ.	5.7 LBS.
11	SN-30	HALF SPOOL-CCV 1 1/2" SQ.	5.7 LBS.
12	SN-39	PIN SET BAR WITH PULL RING	0.21 LBS.
13	X-85	BRG. 1 1/2" SQ. SEALED	2.0 LBS.
14	JXE-18	EXT. WASHER-CVX, 1 1/2" SQ.	9.0 LBS.
15	LW12	LOCK WASHER-SPRING 1/2"	NA
16	LW58	LOCK WASHER-SPRING 5/8"	NA
17	LW112	LOCK WASHER-SPRING 1 1/2"	NA
18	N58	NUT 5/8" NC., HEX.	NA
19	SN112	SLOTTED NUT, 1 1/2" NX, HEX	0.8 LBS.
20	CS12112-5	BLOT 1/2" X 1 1/2" LG. GR. 5	NA
21	CS58134-5	BOLT 5/8" X 1 3/4" LG. GR. 5	NA
22	CS58214-5	BOLT 5/8" X 2 1/4" LG. GR. 5	NA
23	BLD-68	PIN BAR WITH PULL RING	0.21 LBS.
24		DISC BLADES VERY PER. MODEL OF SN-DISC	NA
25	CP3163	COOTER PIN 3/16" X 3" LG.	NA

SN-03-W

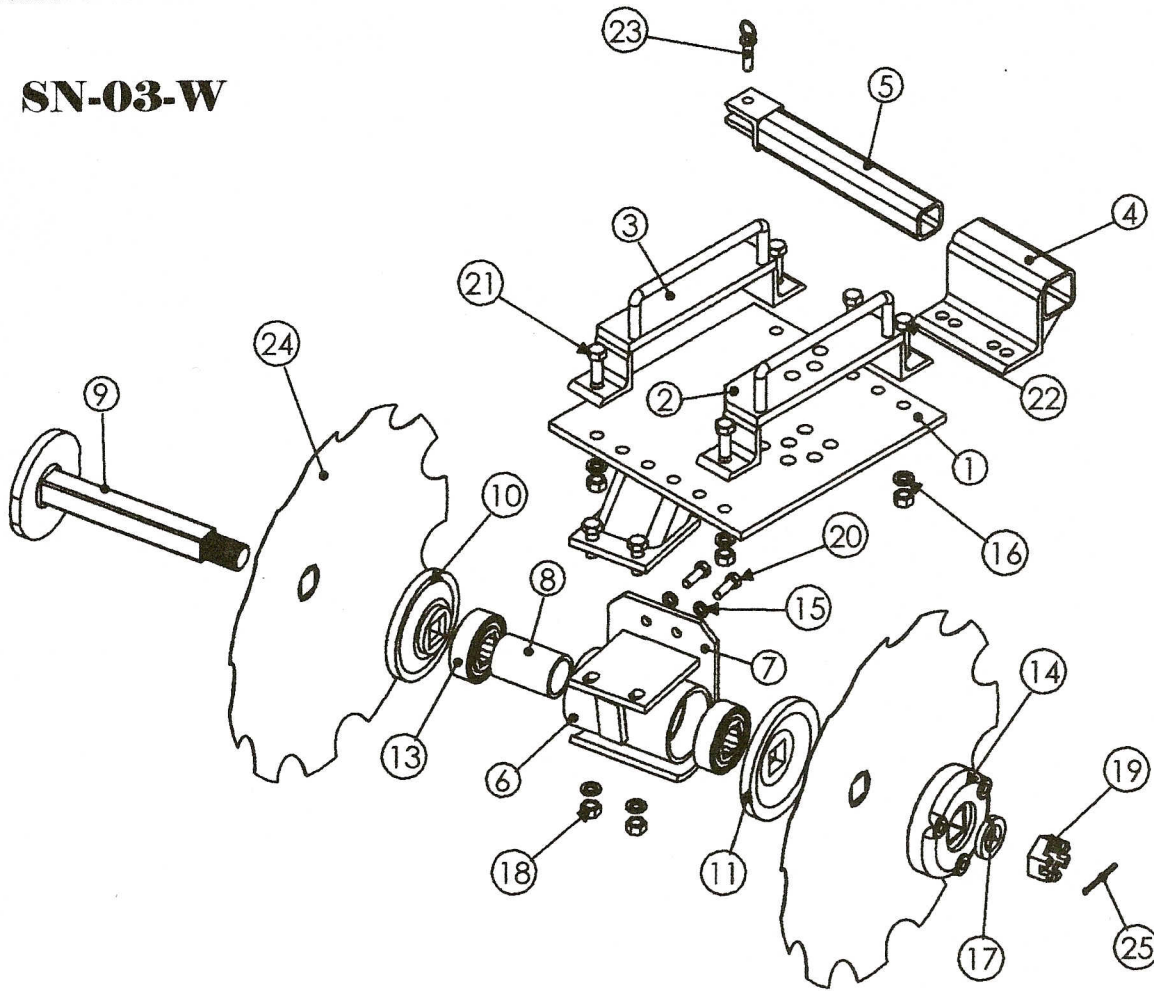

2 BLADED, RIGHT FRONT, 9" SPACING

REF #	PART #	GANG FRAME ASSEMBLY	WT./LB.
1	SN-03-W	GANG FRAME 1" PLATE	85.3 LBS.
2	SN-06	YOKE PIVOT	10.3 LBS.
3	SN-08	YOKE HOLD DOWN	8.6 LBS.
4	SN-09-E	SET BAR HOLDER-EXTENDED	9.3 LBS.
5	SN-10	SET BAR FRONT	6.9 LBS.
6	SN-13	BEARING HOUSING	14.2 LBS.
7	SN-15	WEAR GUARD	14.2 LBS.
8	SN-21	BRG. INSERT	2.4 LBS.
9	SN-26	GANG ROD, 1 1/2" SQ.	12.6 LBS.
10	SN-29	HALF SPOOL-CVX, 1 1/2" SQ.	5.7 LBS.
11	SN-30	HALF SPOOL-CCV 1 1/2" SQ.	5.7 LBS.
12	SN-39	PIN SET BAR WITH PULL RING	0.21 LBS.
13	X-85	BRG. 1 1/2" SQ. SEALED	2.0 LBS.
14	JXE-18	EXT. WASHER-CVX, 1 1/2" SQ.	9.0 LBS.
15	LW12	LOCK WASHER-SPRING 1/2"	N/A
16	LW58	LOCK WASHER-SPRING 5/8"	N/A
17	LW112	LOCK WASHER-SPRING 1 1/2"	N/A
18	N58	NUT 5/8" NC., HEX	N/A
19	SN112	SLOTTED NUT, 1 1/2" NX, HEX	0.8 LBS.
20	CS12112-5	BLOT 1/2" X 1 1/2" LG. GR. 5	N/A
21	CS58134-5	BOLT 5/8" X 1 3/4" LG. GR. 5	N/A
22	CS58214-5	BOLT 5/8" X 2 1/4" LG. GR. 5	N/A
23	BLD-68	PIN BAR WITH PULL RING	0.21 LBS.
24		DISC BLADES VERY PER. MODEL OF SN-DISC	N/A
25	CP3163	COOTER PIN 3/16" X 3" LG.	N/A

SN-05-W

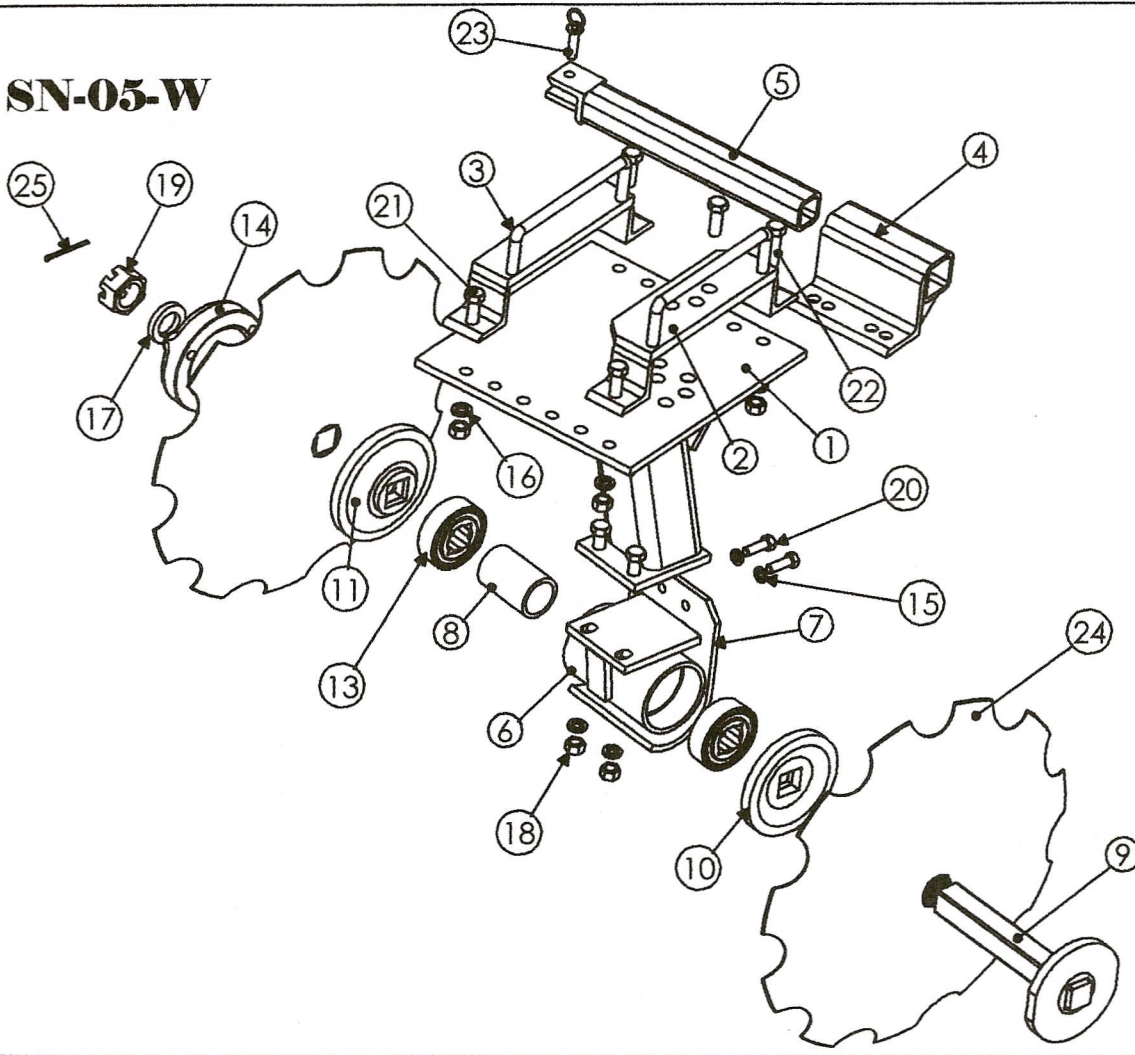

2 BLADED, RIGHT REAR, 7 1/4" SPACING

REF #	PART #	GANG FRAME ASSEMBLY	WT./LB.
1	SN-36-W	GANG FRAME 1" PLATE	85.3 LBS.
2	SN-06	YOKE PIVOT	10.3 LBS.
3	SN-08	YOKE HOLD DOWN	8.8 LBS.
4	SN-09-E	SET BAR HOLDER-EXTENDED	9.3 LBS.
5	SN-11	SET BAR, REAR	6.9 LBS.
6	SN-12	BEARING HOUSING	14.2 LBS.
7	SN-14	WEAR GUARD	14.2 LBS.
8	SN-21	BRG. INSERT	2.4 LBS.
9	SN-26	GANG ROD, 1 1/2" SQ.	12.6 LBS.
10	SN-29	HALF SPOOL-CVX, 1 1/2" SQ.	5.7 LBS.
11	SN-30	HALF SPOOL-CCV 1 1/2" SQ.	5.7 LBS.
12	SN-39	PIN SET BAR WITH PULL RING	0.21 LBS.
13	X-85	BRG. 1 1/2" SQ. SEALED	2.0 LBS.
14	JXE-18	EXT. WASHER-CVX, 1 1/2" SQ.	9.0 LBS.
15	LW12	LOCK WASHER-SPRING 1/2"	N/A
16	LW58	LOCK WASHER-SPRING 5/8"	N/A
17	LW112	LOCK WASHER-SPRING 1 1/2"	N/A
18	N58	NUT 5/8" NC., HEX.	N/A
19	SN112	SLOTTED NUT, 1 1/2" NX, HEX	0.8 LBS.
20	CS12112-5	BLOT 1/2" X 1 1/2" LG. GR. 5	N/A
21	CS58134-5	BOLT 5/8" X 1 3/4" LG. GR. 5	N/A
22	CS58214-5	BOLT 5/8" X 2 1/4" LG. GR.5	N/A
23	BLD-68	PIN BAR WITH PULL RING	0.21 LBS.
24		DISC BLADES VERY PER. MODEL OF SN-DISC	N/A
25	CP3163	COOTER PIN 3/16" X 3" LG.	N/A

SN-36-W

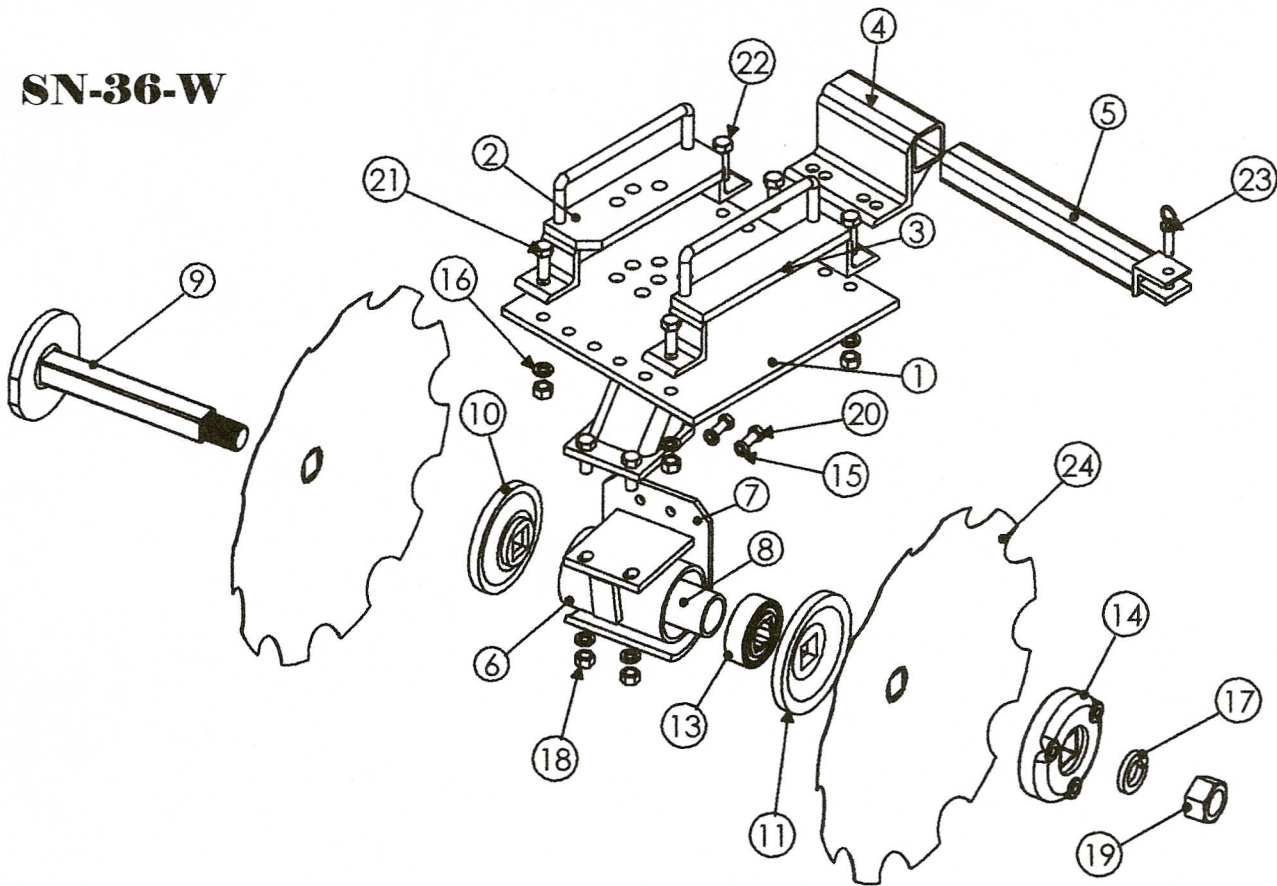

2 BLADED, LEFT REAR, 9" SPACING

REF #	PART #	GANG FRAME ASSEMBLY	WT./LB.
1	SN-36-W	GANG FRAME 1" PLATE	85.3 LBS.
2	SN-06	YOKE PIVOT	10.3 LBS.
3	SN-08	YOKE HOLD DOWN	8.6 LBS.
4	SN-09-E	SET BAR HOLDER-EXTENDED	9.3 LBS.
5	SN-11	SET BAR, REAR	6.9 LBS.
6	SN-13	BEARING HOUSING	14.2 LBS.
7	SN-15	WEAR GUARD	14.2 LBS.
8	SN-21	BRG. INSERT	2.4 LBS.
9	SN-26	GANG ROD, 1 1/2" SQ.	12.6 LBS.
10	SN-29	HALF SPOOL-CVX, 1 1/2" SQ.	5.7 LBS.
11	SN-30	HALF SPOOL-CCV 1 1/2" SQ.	5.7 LBS.
12	SN-39	PIN SET BAR WITH PULL RING	0.21 LBS.
13	X-85	BRG. 1 1/2" SQ. SEALED	2.0 LBS.
14	JXE-18	EXT. WASHER-CVX, 1 1/2" SQ.	9.0 LBS.
15	LW12	LOCK WASHER-SPRING 1/2"	N/A
16	LW58	LOCK WASHER-SPRING 5/8"	N/A
17	LW112	LOCK WASHER-SPRING 1 1/2"	N/A
18	N58	NUT 5/8" NC., HEX	N/A
19	SN112	SLOTTED NUT, 1 1/2" NX, HEX	0.8 LBS.
20	CS12112-5	BLOT 1/2" X 1 1/2" LG. GR. 5	N/A
21	CS58134-5	BOLT 5/8" X 1 3/4" LG. GR. 5	N/A
22	CS58214-5	BOLT 5/8" X 2 1/4" LG. GR. 5	N/A
23	BLD-68	PIN BAR WITH PULL RING	0.21 LBS.
24		DISC BLADES VERY PER. MODEL OF SN-DISC	N/A
25	CP3163	COOTER PIN 3/16" X 3" LG.	N/A

SN-37-W

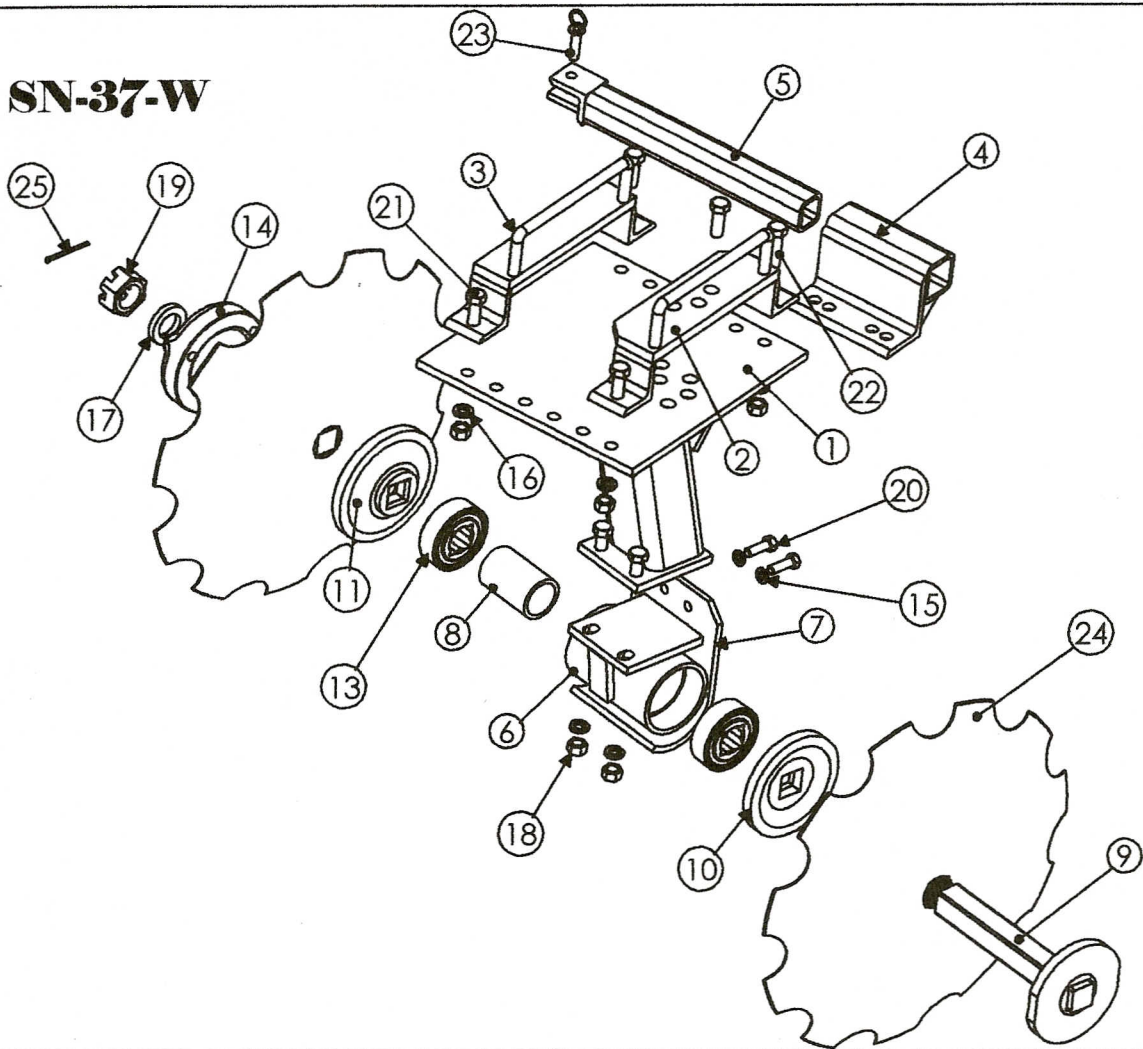

2 BLADED, RIGHT REAR, 9" SPACING

REF #	PART #	GANG FRAME ASSEMBLY	WT./LB.
1	SN-37-W	GANG FRAME 1" PLATE	85.3 LBS.
2	SN-06	YOKE PIVOT	10.3 LBS.
3	SN-08	YOKE HOLD DOWN	8.6 LBS.
4	SN-09-E	SET BAR HOLDER-EXTENDED	9.3 LBS.
5	SN-11	SET BAR, REAR	6.9 LBS.
6	SN-13	BEARING HOUSING	14.2 LBS.
7	SN-15	WEAR GUARD	14.2 LBS.
8	SN-21	BRG. INSERT	2.4 LBS.
9	SN-26	GANG ROD, 1 1/2" SQ.	12.6 LBS.
10	SN-29	HALF SPOOL-CVX, 1 1/2" SQ.	5.7 LBS.
11	SN-30	HALF SPOOL-CCV 1 1/2" SQ.	5.7 LBS.
12	SN-39	PIN SET BAR WITH PULL RING	0.21 LBS.
13	X-85	BRG. 1 1/2" SQ. SEALED	2.0 LBS.
14	JXE-18	EXT. WASHER-CVX, 1 1/2" SQ.	9.0 LBS.
15	LW12	LOCK WASHER-SPRING 1/2"	N/A
16	LW58	LOCK WASHER-SPRING 5/8"	N/A
17	LW112	LOCK WASHER-SPRING 1 1/2"	N/A
18	N58	NUT 5/8" NC., HEX	N/A
19	SN112	SLOTTED NUT, 1 1/2" NX, HEX	0.8 LBS.
20	CS12112-5	BLOT 1/2" X 1 1/2" LG. GR. 5	N/A
21	CS58134-5	BOLT 5/8" X 1 3/4" LG. GR. 5	N/A
22	CS58214-5	BOLT 5/8" X 2 1/4" LG. GR. 5	N/A
23	BLD-68	PIN BAR WITH PULL RING	0.21 LBS.
24		DISC BLADES VERY PER. MODEL OF SN-DISC	N/A
25	CP3163	COOTER PIN 3/16" X 3" LG.	N/A

SN-50-W

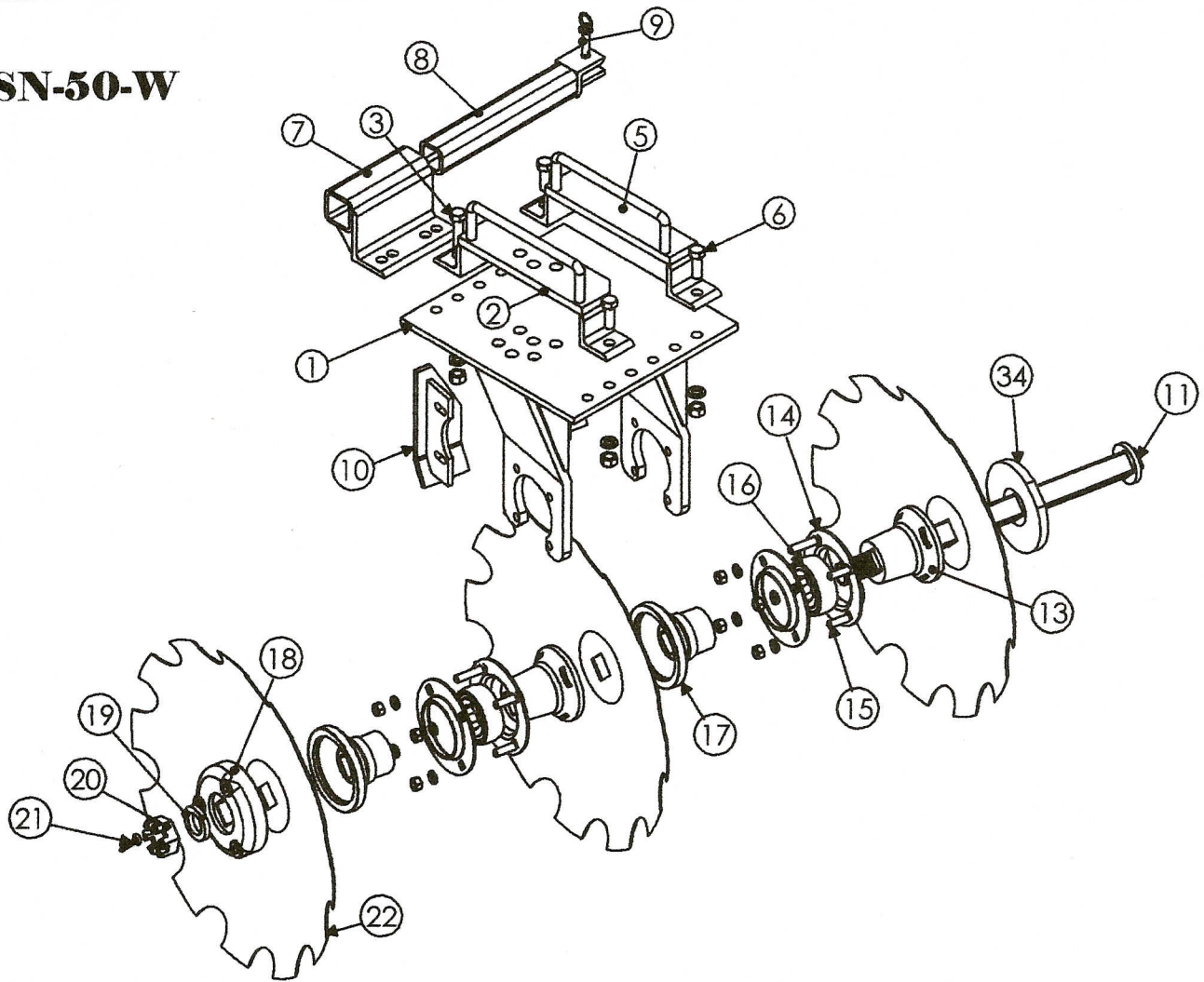

3 BLADED , LEFT FRONT, 9" SPACING

REF #	PART #	GANG FRAME ASSEMBLY	WT./LB.
1	SN-50-W	GANG FRAME - 1" PLATE	105.0 LBS.
2	SN-06	YOKE PIVOT	10.3 LBS
3	CS58214-5	BOLT 5/8" X 2 1/4" LG. GR.5	N/A
4	SN-39	PIVOT PIN	0.7 LBS.
5	SN-08	YOKE HOLD DOWN	8.8 LBS.
6	CS58134-5	BOLT 5/8" X 1 3/4" LG. GR.5	N/A
7	SN-09-E	SET BAR HOLDER-EXTENDED	9.3 LBS.
8	SN-10	SET BAR FRONT	6.9 LBS.
9	BLD-68	PIN - SET BAR WITH PULL RING	0.21 LBS.
10	SN-61	WEAR GUARD (FLANGE TYPE)	6.0 LBS.
11	XGR-3	GANG ROD - 1 1/2" SQ., 3 BLADE	14.0 LBS.
12	X-98	END WASHER-1 1/2" SQ.	4.7 LBS.
13	XJ-84	HALF SPOOL- CVX, 1 1/2" SQ.	5.7 LBS.
14	NV-100	FLANGETTE- PR, BEARING	1.0 LBS.
15	CB12134-5	CARRIAGE BOLT 1/2" X 1 3/4" LG. GR.5	0.1 LBS.
16	NV-211	FLANGE BEARING - 1 1/2" SQ., SEALED	1.0 LBS.
17	XJ-83	HALF SPOOL- CCV, 1 1/2" SQ.	6.5 LBS.
18	JXE-18	EXT. WASHER - CVX, 1 1/2" SQ.	9.0 LBS.
19	LW112	LOCK WASHER - 1 1/2"	0.2 LBS.
20	SN112	SLOTTED NUT, 1 1/2"	0.8 LBS.
21	CP3163	COTTER PIN 3/16" X 3" LG.	0.1 LBS.
22		DISC BLADES VERY PER. MODEL	N/A

SN-51-W

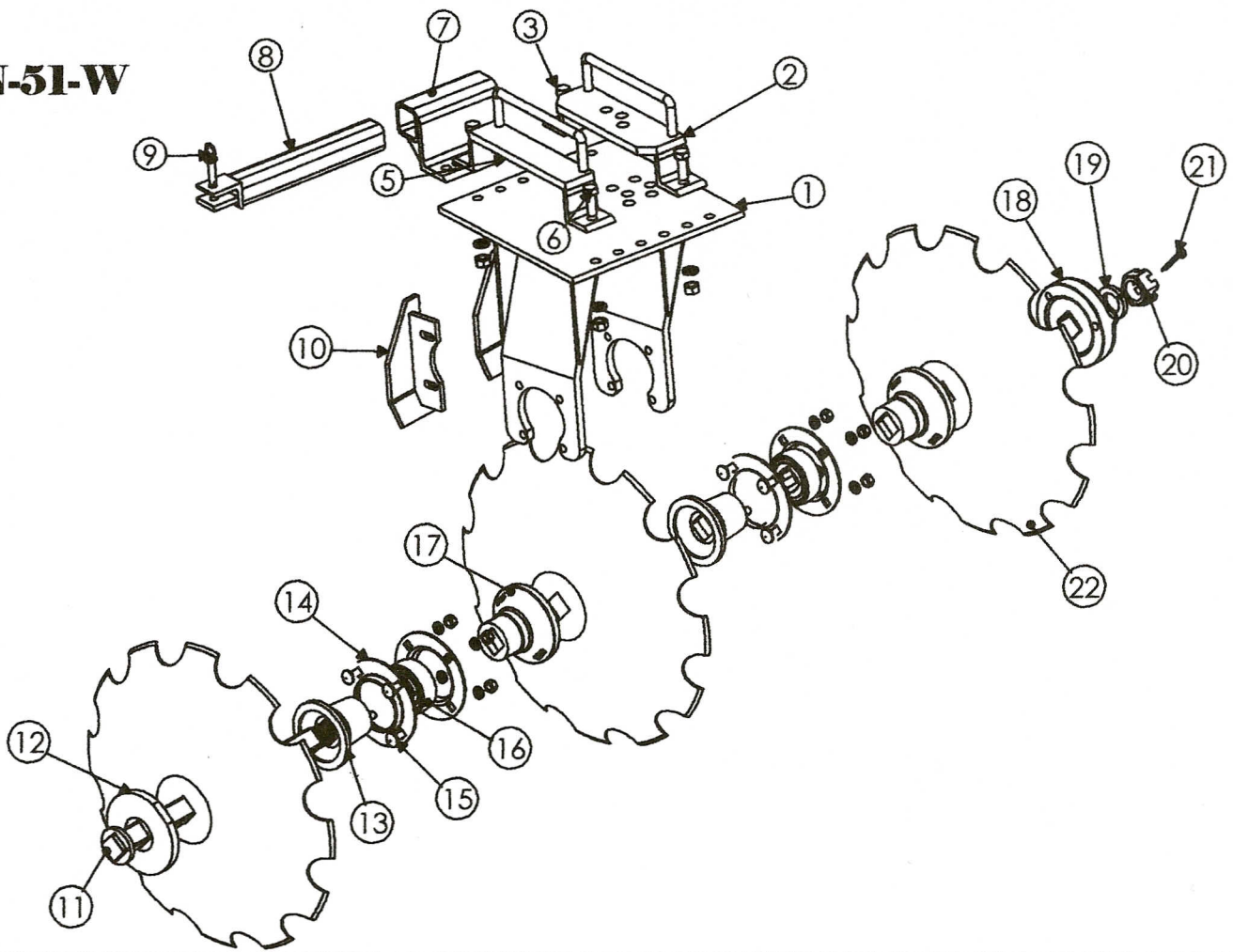

3 BLADED, RIGHT FRONT, 9" SPACING

REF #	PART #	GANG FRAME ASSEMBLY	WT./LB.
1	SN-51-W	GANG FRAME - 1" PLATE	105.0 LBS.
2	SN-07	YOKE PIVOT	10.3 LBS
3	CS58214-5	BOLT 5/8" X 2 1/4" LG. GR.5	N/A
4	SN-39	PIVOT PIN	0.7 LBS.
5	SN-08	YOKE HOLD DOWN	8.8 LBS.
6	CS58134-5	BOLT 5/8" X 1 3/4" LG. GR.5	N/A
7	SN-09-E	SET BAR HOLDER-EXTENDED	9.3 LBS.
8	SN-10	SET BAR FRONT	6.9 LBS.
9	BLD-68	PIN - SET BAR WITH PULL RING	0.21 LBS.
10	SN-61	WEAR GUARD (FLANGE TYPE)	6.0 LBS.
11	XGR-3	GANG ROD - 1 1/2" SQ., 3 BLADE	14.0 LBS.
12	X-98	END WASHER-1 1/2" SQ.	4.7 LBS.
13	XJ-84	HALF SPOOL- CVX 1 1/2" SQ.	5.7 LBS.
14	NV-100	FLANGETTE- PR, BEARING	1.0 LBS.
15	CB12134-5	CARRIAGE BOLT 1/2" X 1 3/4" LG. GR.5	0.1 LBS.
16	NV-211	FLANGE BEARING - 1 1/2" SQ., SEALED	1.0 LBS.
17	XJ-83	HALF SPOOL- CCV, 1 1/2" SQ.	6.5 LBS.
18	JXE-18	EXT. WASHER - CVX, 1 1/2" SQ.	9.0 LBS.
19	LW112	LOCK WASHER - 1 1/2"	0.2 LBS.
20	SN112	SLOTTED NUT, 1 1/2"	0.8 LBS.
21	CP3163	COTTER PIN 3/16" X 3" LG.	0.1 LBS.
22		DISC BLADES VERY PER. MODEL	N/A

SN-52-W

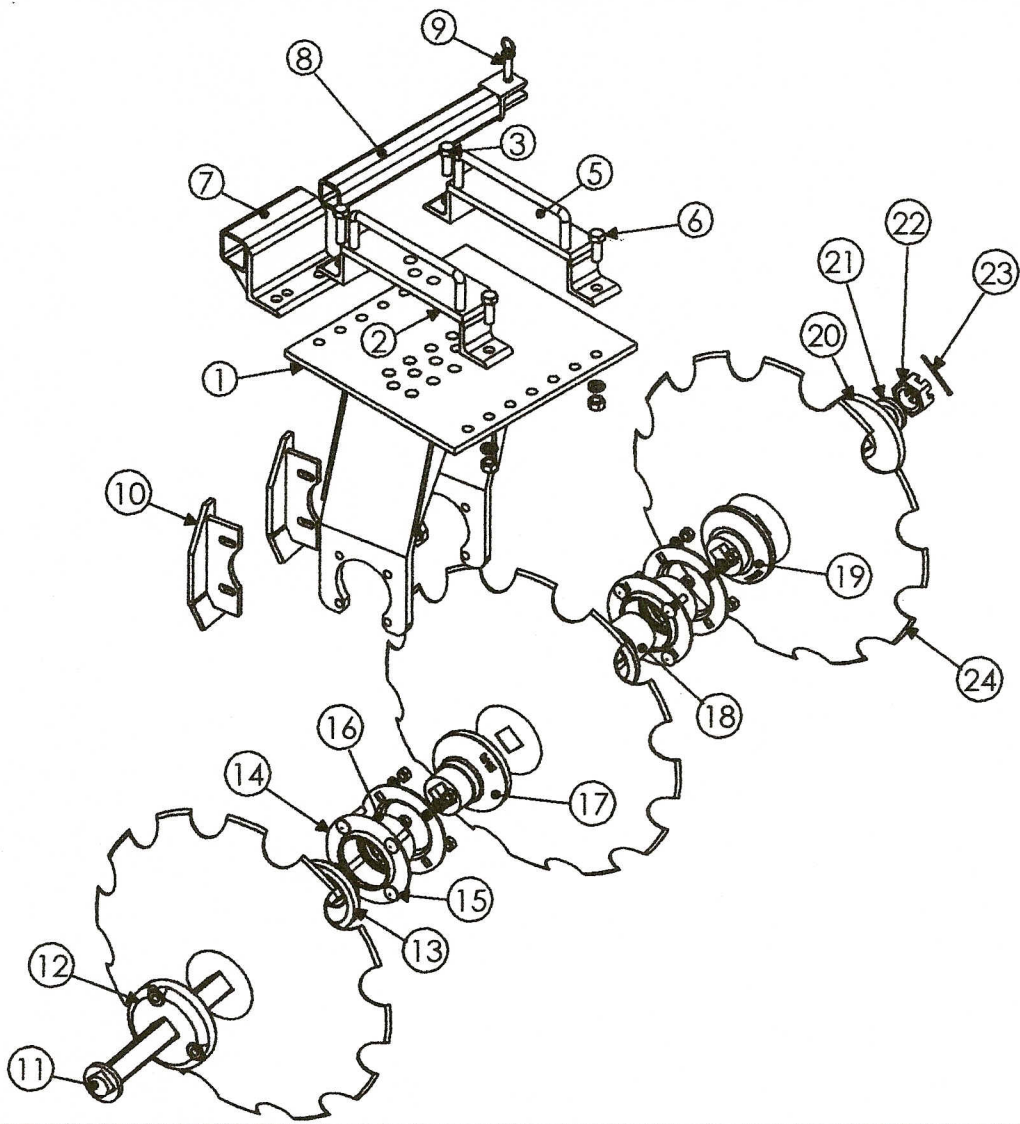

3 BLADED, LEFT REAR, 7 1/4" SPACING

REF #	PART #	GANG FRAME ASSEMBLY	WT./LB.
1	SN-52-W	GANG FRAME - 1" PLATE	105.0 LBS.
2	SN-07	YOKE PIVOT	10.3 LBS.
3	CS58214-5	BOLT 5/8" X 2 1/4" LG. GR.5	N/A
4	SN-39	PIVOT PIN	0.7 LBS.
5	SN-08	YOKE HOLD DOWN	8.8 LBS.
6	CS58134-5	BOLT 5/8" X 1 3/4" LG. GR.5	N/A
7	SN-09-E	SET BAR HOLDER-EXTENDED	9.3 LBS.
8	SN-11	SET BAR REAR	8.0 LBS.
9	BLD-68	PIN - SET BAR WITH PULL RING	0.21 LBS.
10	SN-62	WEAR GUARD (FLANGE TYPE) 7 1/4"S.P.C.	5.4 LBS.
11	SN-72	GANG ROD - 1 1/2" SQ., 3 BLADE	14.0 LBS.
12	JXE-19	EXT. WASHER - CCV, 1 1/2" SQ.	8.0 LBS.
13	BDX-84	HALF SPOOL - CVX, 1 1/2" SQ.	4.0 LBS.
14	NV-100	FLANGETTE - PR, BEARING	1.0 LBS.
15	CB12134-5	CARRIAGE BOLT 1/2" X 1 3/4" LG. GR.5	0.1 LBS.
16	NV-211	FLANGE BEARING - 1 1/2" SQ., SEALED	1.0 LBS.
17	XJ-83	HALF SPOOL - CCV, 1 1/2" SQ.	6.5 LBS.
18	XJ-84	HALF SPOOL - CVX, 1 1/2" SQ.	5.7 LBS.
19	BDX-83	HALF SPOOL - CCV, 1 1/2" SQ. (TRIM TO FIT FLANGE)	4.5 LBS.
20	X-88	END WASHER - 1 1/2" SQ. - STEEL	5.0 LBS.
21	LW112	LOCK WASHER - 1 1/2"	0.2 LBS.
22	SN112	SLOTTED NUT, 1 1/2"	0.8 LBS.
23	CP3163	COTTER PIN 3/16" X 3" LG.	0.1 LBS.
24		DISC BLADES VERY PER. MODEL	N/A

SN-53-W

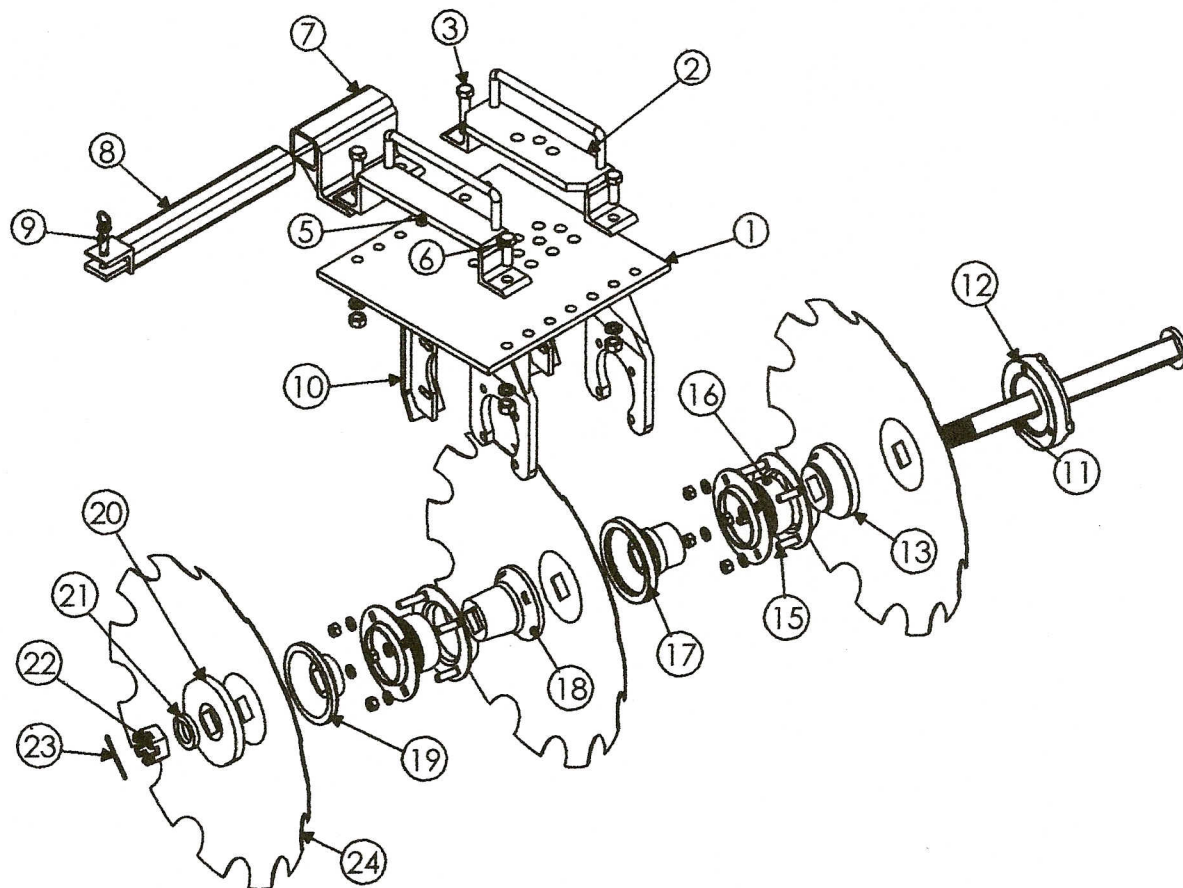

3 BLADED, RIGHT REAR, 7 1/4" SPACING

REF #	PART #	GANG FRAME ASSEMBLY	WT./LB.
1	SN-53-W	GANG FRAME - 1" PLATE	105.0 LBS.
2	SN-06	YOKE PIVOT	10.3 LBS
3	CS58214-5	BOLT 5/8" X 2 1/4" LG. GR.5	N/A
4	SN-39	PIVOT PIN	0.7 LBS.
5	SN-08	YOKE HOLD DOWN	8.8 LBS.
6	CS58134-5	BOLT 5/8" X 1 3/4" LG. GR.5	N/A
7	SN-09-E	SET BAR HOLDER-EXTENDED	9.3 LBS.
8	SN-11	SET BAR REAR	8.0 LBS.
9	BLD-68	PIN - SET BAR WITH PULL RING	0.21 LBS.
10	SN-63	WEAR GUARD (FLANGE TYPE) 7 1/4" SPC.	5.4 LBS.
11	SN-72	GANG ROD - 1 1/2" SQ., 3 BLADE	14.0 LBS.
12	JXE-19	EXT. WASHER - CCV, 1 1/2" SQ.	8.0 LBS.
13	BDX-84	HALF SPOOL - CVX, 1 1/2" SQ.	4.0 LBS
14	NV-100	FLANGETTE - PR, BEARING	1.0 LBS.
15	CB12134-5	CARRIAGE BOLT 1/2" X 1 3/4" LG. GR.5	0.1 LBS.
16	NV-211	FLANGE BEARING - 1 1/2" SQ., SEALED	1.0 LBS
17	XJ-83	HALF SPOOL - CCV, 1 1/2" SQ.	6.5 LBS.
18	XJ-84	HALF SPOOL - CVX, 1 1/2" SQ.	5.7 LBS.
19	BDX-83	HALF SPOOL - CCV, 1 1/2" SQ. (TRIM TO FIT FLANGE)	4.5 LBS.
20	X-98	END WASHER - 1 1/2" SQ. - STEEL	5.0 LBS.
21	LW112	LOCK WASHER - 1 1/2"	0.2 LBS.
22	SN112	SLOTTED NUT, 1 1/2"	0.8 LBS.
23	CP3163	COTTER PIN 3/16" X 3" LG.	0.1 LBS.
24		DISC BLADES VERY PER. MODEL	N/A

SN-52W

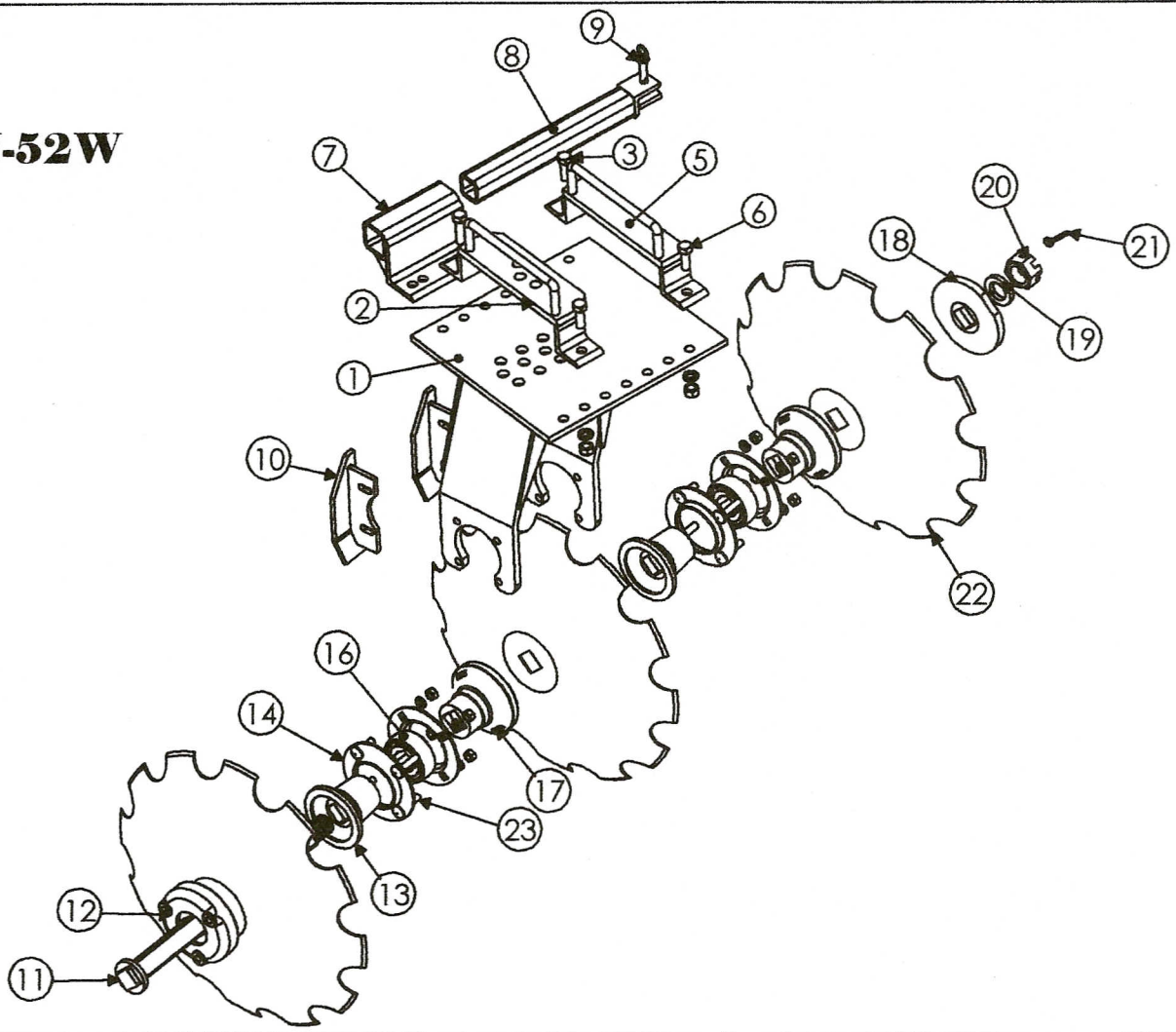

3 BLADED, LEFT REAR, 9" SPACING

REF #	PART #	GANG FRAME ASSEMBLY	WT./LB.
1	SN-52-W	GANG FRAME - 1" PLATE	110.0 LBS.
2	SN-07	YOKE PIVOT	10.3 LBS
3	CS58214-5	BOLT 5/8" X 2 1/4" LG. GR.5	N/A
4	SN-39	PIVOT PIN	0.7 LBS.
5	SN-08	YOKE HOLD DOWN	8.8 LBS.
6	CS58134-5	BOLT 5/8" X 1 3/4" LG. GR.5	N/A
7	SN-09-E	SET BAR HOLDER-EXTENDED	9.3 LBS.
8	SN-11	SET BAR REAR	8.0 LBS.
9	BLD-68	PIN - SET BAR WITH PULL RING	0.21 LBS.
10	SN-61	WEAR GUARD (FLANGE TYPE)	6.0 LBS.
11	XGR-3	GANG ROD - 1 1/2" SQ., 3 BLADE	14.0 LBS.
12	JXE-19	EXT. WASHER - CCV, 1 1/2" SQ.	8.0 LBS.
13	XJ-84	HALF SPOOL- CVX, 1 1/2" SQ.	5.7 LBS.
14	NV-100	FLANGETTE- PR, BEARING	1.0 LBS.
15	CB12134-5	CARRIAGE BOLT 1/2" X 1 3/4" LG. GR.5	0.1 LBS.
16	NV-211	FLANGE BEARING - 1 1/2" SQ., SEALED	1.0 LBS.
17	XJ-83	HALF SPOOL- CCV, 1 1/2" SQ.	6.5 LBS.
18	X-98	END WASHER-1 1/2" SQ. - STEEL	4.7 LBS.
19	LW112	LOCK WASHER - 1 1/2"	0.2 LBS.
20	SN112	SLOTTED NUT, 1 1/2"	0.8 LBS.
21	CP3163	COTTER PIN 3/16" X 3" LG.	0.1 LBS.
22		DISC BLADES VERY PER. MODEL	N/A

SN-53-W

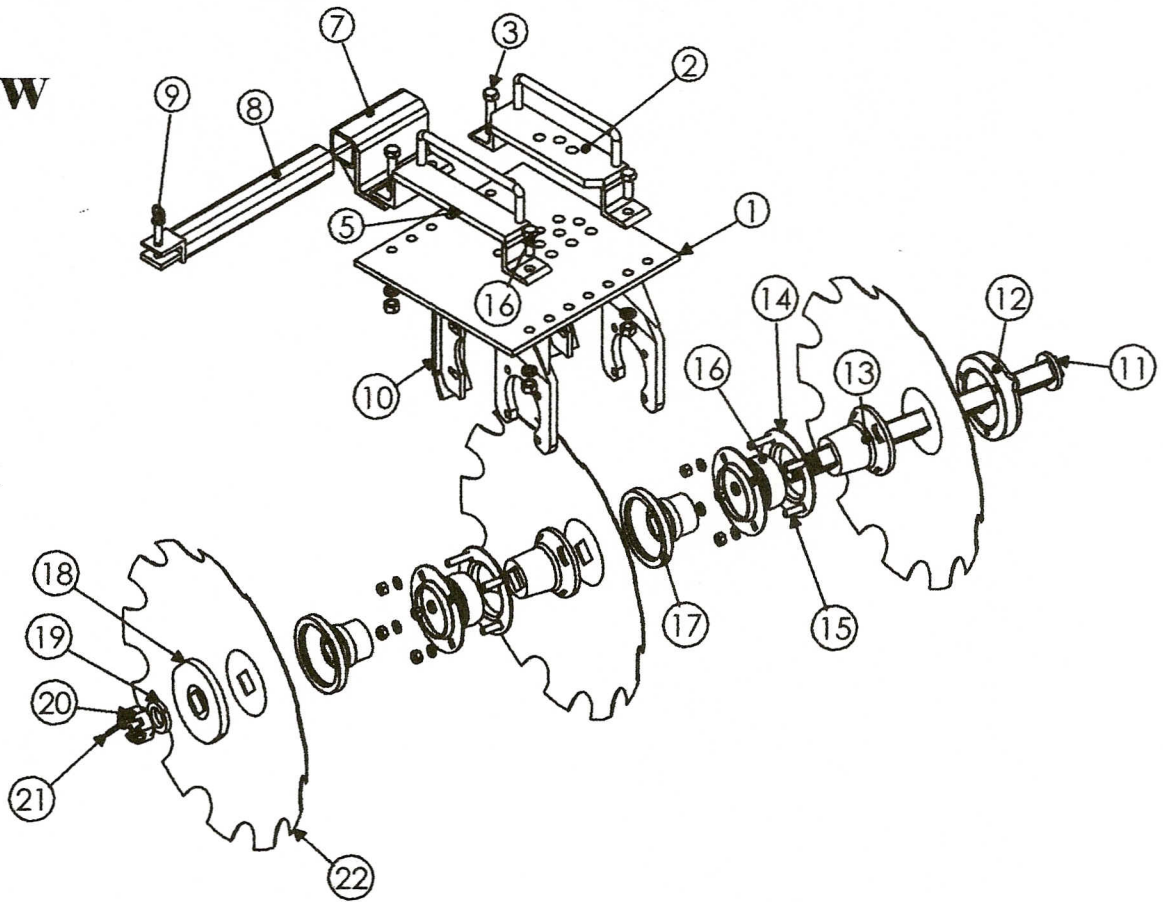

3 BLADED, RIGHT REAR, 9" SPACING





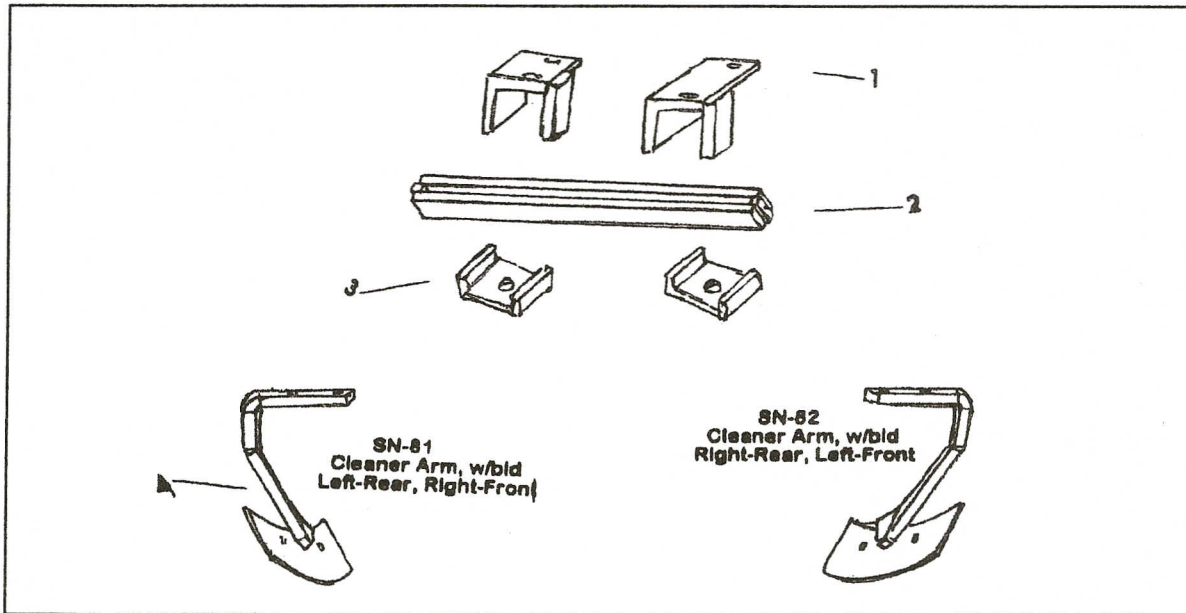







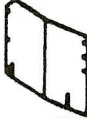
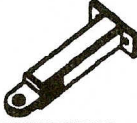

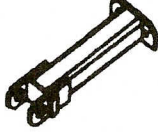

REF #	PART #	GANG FRAME ASSEMBLY	WT./LB.
1	SN-53-W	GANG FRAME - 1" PLATE	110.0 LBS.
2	SN-06	YOKE PIVOT	10.3 LBS.
3	CS58214-5	BOLT 5/8" X 2 1/4" LG. GR.5	N/A
4	SN-39	PIVOT PIN	0.7 LBS.
5	SN-08	YOKE HOLD DOWN	8.8 LBS.
6	CS58134-5	BOLT 5/8" X 1 3/4" LG. GR.5	N/A
7	SN-09-E	SET BAR HOLD-EXTENDED	9.3 LBS.
8	SN-11	SET BAR REAR	8.0 LBS.
9	BLD-68	PIN - SET BAR WITH PULL RING	0.21 LBS.
10	SN-60	WEAR GUARD (FLANGE TYPE)	6.0 LBS.
11	XGR-3	GANG ROD - 1 1/2" SQ., 3 BLADE	14.0 LBS.
12	JXE-19	EXT. WASHER - CCV, 1 1/2" SQ.	8.0 LBS.
13	XJ-84	HALF SPOOL- CVX, 1 1/2" SQ.	5.7 LBS.
14	NV-100	FLANGETTE- PR, BEARING	1.0 LBS.
15	CB12134-5	CARRIAGE BOLT 1/2" X 1 3/4" LG. GR.5	0.1 LBS.
16	NV-211	FLANGE BEARING - 1 1/2" SQ., SEALED	1.0 LBS.
17	XJ-83	HALF SPOOL- CCV, 1 1/2" SQ.	6.5 LBS.
18	X-98	END WASHER-1 1/2" SQ. - STEEL	4.7 LBS.
19	LW112	LOCK WASHER - 1 1/2"	0.2 LBS.
20	SN112	SLOTTED NUT, 1 1/2"	0.8 LBS.
21	CP3163	COTTER PIN 3/16" X 3" LG.	0.1 LBS.
22		DISC BLADES VERY PER. MODEL	N/A

SN-CLEANERS













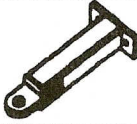





REF. NO.	PART NO.	QTY	DESCRIPTION OTH	APPROX WT.
1	SN-16		Bracket Cleaner Bar - Long	
	SN-17		Bracket Cleaner Bar - Short	
2	SN-18		Cleaner Bar - 2 Bld 9" Spcg - 18" lg	
	SN-19		Cleaner Bar - 2 Bld 7.25" Spcg - 15" lg	
	SN-43		Cleaner Bar - 3 Bld 9" Spcg - 24" lg	
	SN-44		Cleaner Bar - 3 Bld 7.25" Spcg - 20" lg	
	SN-45		Cleaner Bar - 4 Bld 9" Spcg - 33" lg	
	SN-46		Cleaner Bar - 4 Bld 7.25" Spcg - 28" lg	
	SN-47		Cleaner Bar - 5 Bld 9" Spcg - 42" lg	
3	RPO-120		Clip - Cleaner Bar	
4	SN-81		Cleaner Arm w/Bld. - L Rear & R Front	
	SN-82		Cleaner Arm w/Bld. - R Rear & L Front	
	CS12412-5		Bolt - 1/2"nc x 4 1/2"lg Gr.5 (Hardware for Bracket, Cleaner Bar Clip)	
	LW12		Lock washer - 1/2"	
	N12		Nut 1/2"	
	CB12312-5		Bolt - 1/2"nc x 3 1/2"lg Gr.5 (Hardware for Cleaner Arms to Cleaner Bar)	
	LW12		Lock washer - 1/2"	
	N12		Nut 1/2"	
	CS58214-5		Bolt - 1/2"nc x 4 1/2"lg Gr.5 (Hardware for Bracket)	
	LW58		Lock washer - 5/8"	
	N58		Nut 5/8"	

ADDITIONAL OPTIONS FOR SN DISC

Dirt Shields		Tow Hitch			
1		SN-33 Dirt Shield-Left 30.3 lbs.	12		SN-35 Hitch Tow, 7.93 lbs.
2		SN-34 Dirt Shield-Right 30.3 lbs.	13		SN-38 Hitch Tow, 7.93 lbs.
3		SN-87 Shield Extend Left Rear Sec.	14		SN-90 Hitch Tow, Short Swivel 12.05 lbs.
4		SN-88 Shield Extend Right Rear Sec.	15		SN-81 Hitch Tow, Long Swivel 20.05 lbs.
5		SN-33-B Dirt Shield-Left Belted	16		SN-97 Bracket Tow, Tow Hitch 5.93 lbs.
6		SN-34-B Dirt Shield-Right Belted	17		SN-98 Clevis, Tow Hitch 8.96 lbs.
7		SN-74 Dirt Shield Extension Left	18		SN-99 Single, Tow Hitch
8		SN-75 Dirt Shield Extension Right			
9 10		SN-83 Extension Dirt Shield Adapter.			
11		SN-86 Shield Ext. Rear Sec.			

ADDITIONAL OPTIONS FOR SN DISC

Dirt Shields			Tow Hitch		
1		SN-33 Dirt Shield-Left 30.3 lbs.	12		SN-35 Hitch Tow, 7.93 lbs.
2		SN-34 Dirt Shield-Right 30.3 lbs.	13		SN-38 Hitch Tow, 7.93 lbs.
3		SN-87 Shield Extend Left Rear Sec.	14		SN-90 Hitch Tow, Short Swivel 12.05 lbs.
4		SN-88 Shield Extend Right Rear Sec.	15		SN-91 Hitch Tow, Long Swivel 20.05 lbs.
5		SN-33-B Dirt Shield-Left Belted	16		SN-97 Bracket Tow, Tow Hitch 5.93 lbs.
6		SN-34-B Dirt Shield-Right Belted	17		SN-98 Clevis, Tow Hitch 8.96 lbs.
7		SN-74 Dirt Shield Extension Left	18		SN-99 Single, Tow Hitch
8		SN-75 Dirt Shield Extension Right			
9 10		SN-83 Extension Dirt Shield Adapter.			
11		SN-86 Shield Ext. Rear Sec.			

SN EXTENSION ASSEMBLY

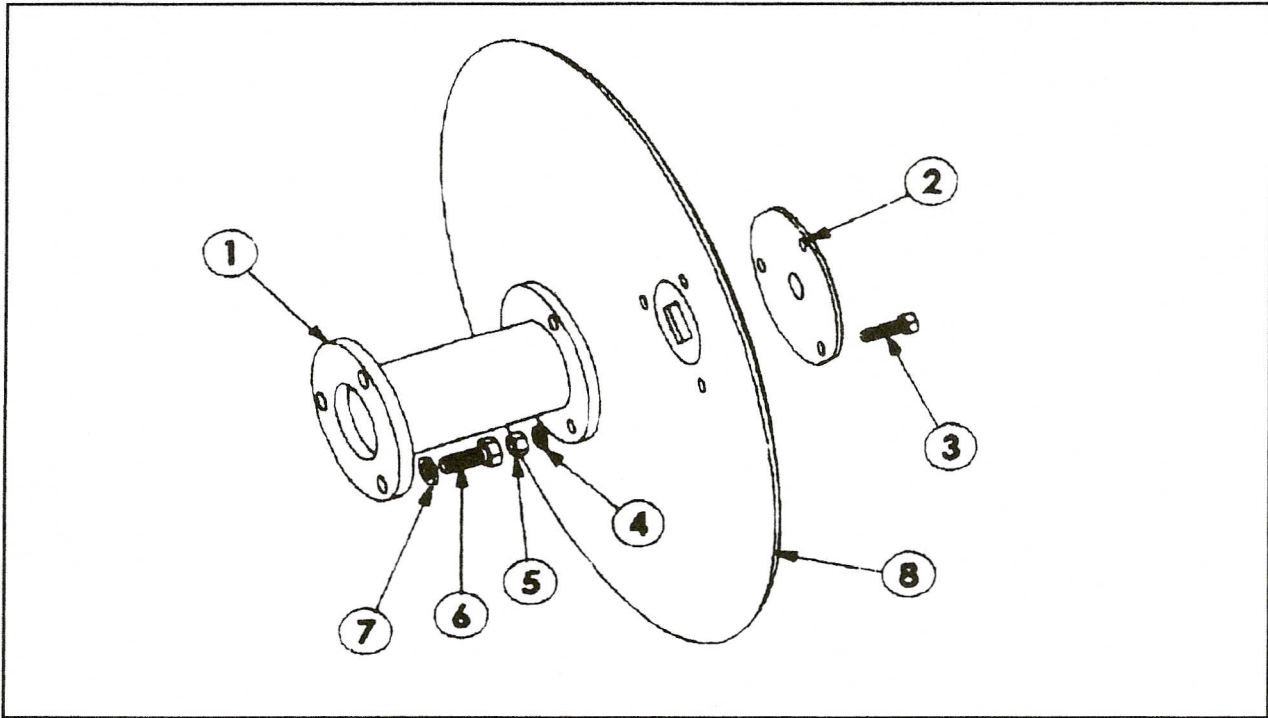

REF. NO.	PART NO.	QTY	DESCRIPTION OTH	APPROX WT.
1	SN-22		Ext. Spool - Frnt - Throw Out 7.25 scp CCV	
	SN-23		Ext. Spool - Rr - Pulls In 7.25 scp CVX	
	JXE-16		Ext. Spool - Frnt - Throw Out 9 scp CCV	
	JXE-17		Ext. Spool - Rr - Pulls In 9 scp CVX	
2	JXE-20		End Cap - Ext. Spool	
3	CS12112-5		Bolt - 1/2" x 1 1/2" lg Gr5	
4	LW12		Lock Washer - 1/2"	
5	N12		Nut - 1/2"	
6	CS58112-5		Bolt - 5/8" x 1 1/2" lg Gr5	
7	LW58		Lock Washer - 5/8"	
8			DETERMINED BY MODEL OF SN DISC	