

SERIES OFM-W

Wheel Type

Offset Disc

Harrow

Semi Finish

Disc

Wing Fold

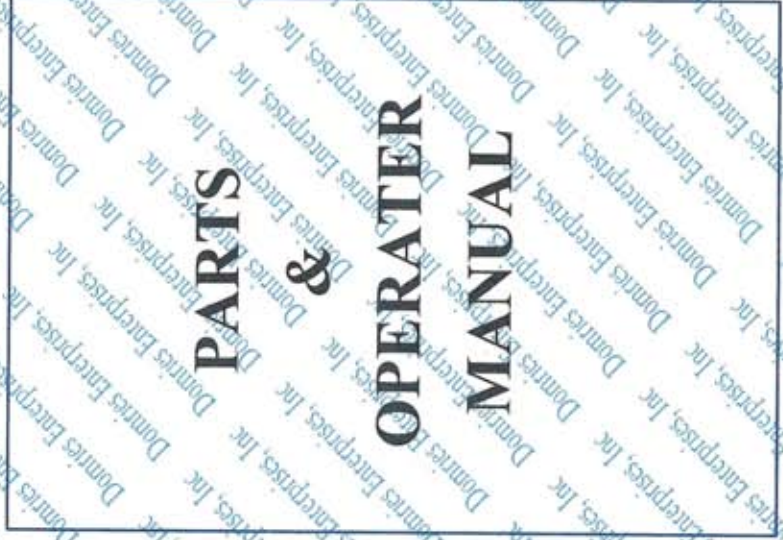

Domreis Enterprises, Inc

12281 Rd 29

Madera, Ca 93638

Phone # (559) 673-9143 Fax # (559) 673-4110

Visit our Web-Site at www.domreientinc.com

IMPORTANT! PLEASE READ!

TO OUR CUSTOMER – USER'S RESPONSIBILITY – WARRANTY

TO OUR CUSTOMER

The following pages and illustrations are printed to help supply you with the knowledge to better operate and service your new **DOMRIES** equipment.

We are proud to have you as a customer and feel you will be proud to be a **DOMRIES** owner.

Any piece of equipment needs, and must have a certain amount of service and maintenance to keep it in top running condition. We have attempted to cover all the adjustments required to fit most conditions; however, there may be times special care must be taken to fit a condition.

Study this operator's manual carefully and become acquainted with all the adjustments and operating procedures before attempting to operate your new equipment. Remember, it is a machine and has been designed and tested to do an efficient job in most operating conditions and will perform in relation to the service it receives.

If special attention is required for some conditions, ask your **DOMRIES** dealer; his Parts and Service Organization will be glad to help and answer any question on operation and service of your new machine.

ATTENTION! BECOME ALERT!

YOUR SAFETY IS INVOLVED

This symbol is used to call your attention to safety precautions that should be followed by the operator to avoid accidents. When you see this symbol – Heed Its Warning.

USER'S RESPONSIBILITY

It is the responsibility of the user to read the Operator's Manual and understand the safe and correct operating procedures as pertains to the operation of the product, and to lubricate and maintain the product according to the maintenance schedule in the Operator's Manual.

The user is responsible for inspecting his machine and for having parts repaired or replaced when continued use of the product would cause damage or excessive wear to other parts. It is the user's responsibility to deliver his machine to a **DOMRIES** dealer, for service or replacement of defective parts which are covered by the standard warranty. When requesting warranty service, you present your copy of delivery record.

MODEL# _____

SERIAL# _____



Safety Precautions

**ATTENTION! BECOME ALBERT!
YOUR SAFETY IS INVOLVED!**

This symbol is used to call your attention to safety precautions. That should be followed by the operator to avoid accidents. When you see this – Heed Its Warning.

Many hours of lost time and much suffering is caused by the failure to practice simple safety rules.

1. **READ** this manual carefully to acquaint your - self with the Disk Harrow. Opening unfamiliar equipment can cause accidents.
2. **LOWER IMPLEMENT** if possible, when adjusting maintenance work; otherwise **BLOCKS IT SECURELY** at a workable height.
3. When Implement and tractor are parked always lower disk to the ground and place a **FLAG OR OTHER WAARMING DEVICE** on each corner as someone could run or bump into the implement.
4. Implement should be **DETACHED ONLY** in an area where Children **DO NOT PLAY**.
5. **DO NOT** wear loose fitting clothing that could catch on various parts.
6. Machinery should be **OPERATED ONLY** by those who are **RESPONSIBLE AND DEEGATED** to do so.
7. **ONLY ONE PERSON** – the operator – should be permitted on the tractor when implement is in operation, he should be thoroughly familiar with tractor and implement.
8. **MAKE CERTAIN** that everyone is in clear before starting tractor and implement combination.
9. **BEFORE WORKING** under the any hydraulically controlled unit IS SURE it is **SECURELY BLOCKED**.
10. The **RATE OF SPEED** on hillsides or curves should be regulated so there is no danger of tipping.
11. **DO Not** drive too close to the edge of a ditch or creek.
12. **REDUCE SPEED** when transporting unit to avoid bouncing and momentary loss of steer ability.
13. **MAKE CERTAIN** tractor is equipped with sufficient front end weight to counter-balance the plow weight and maintain stability of front of tractor.
14. **DO NOT** attempt to operate tractor and implement unless you are in the diver seat.
15. **ALWAYS** place transmission in **PARK or NEUTRAL, LOCK BRAKES, STOP ENGINE AND REMOVE START KEY** before dismounting from the tractor.
16. **NEVER** stand between tractor and disc when hitching.
17. **PROVIDE** a first aid kit. Treat all scratches, cuts, etc. with proper antiseptic immediately.
18. If **DECALS** become damaged or come off, they should be replaced immediately.
19. **REMEMBER** that safe operation is no accident.

ON HIGHWAY OPERATION

1. Use the **SLOW MOVING** vehicle emblem in daytime and approved warning lights at night, or during other periods of poor visibility, to prevent highway accidents.
2. **COMPLY** with Local highway regulation concerning moving machinery on highways.
3. **MAINTAIN** complete Control of machines at all times when traveling on the highway.
4. Due to the width of the implement, **US EXTRA CAUTION** on highways, far lanes and when approaching gates.

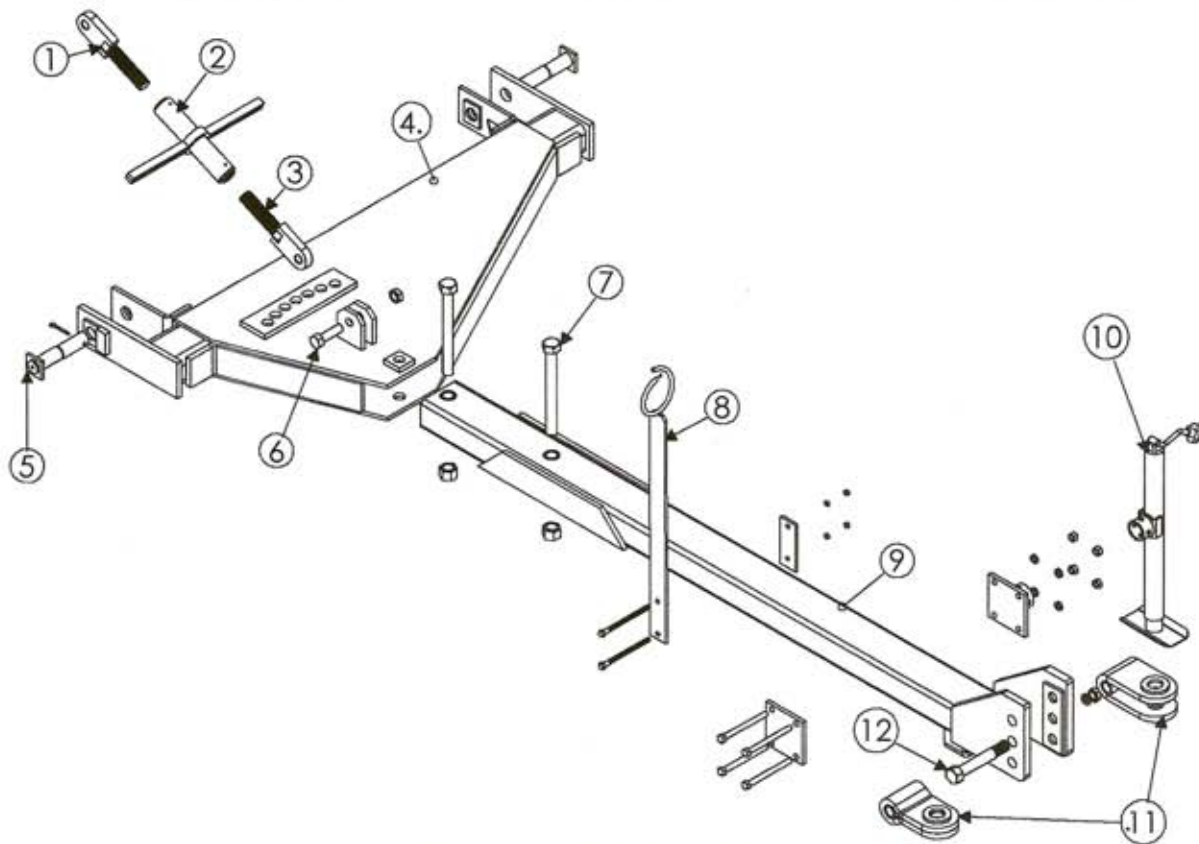

HITCH ASSEMBLY

REF#	PART #	DESCRIPTION	WT/LB.
1	OX-9	BOLT - TURNBUCKLE, R.H. THRD.	6.5 LBS.
2	OX-10	BODY - TURNBUCKLE	14.75 LBS.
3	OX-11	BOLT - TURNBUCKLE, L.H. THRD.	6.5 LBS.
4	OM-5	CROSS MEMBER - HITCH	490.0 LBS.
5	ON-61	PIN - HITCH	5.5 LBS.
6	CS1312-5 LN1	BOLT - 1" X 3 1/2" LG. GR. 5 LOCK NUT - 1"	1.1 LBS. .1 LBS.
7	SC11412-8 N114	BOLT - 1 1/4" X 12" LG. GR. 8 NUT-1 1/4"	N/A N/A
8	ON-139 CS12712-5 LW12 N12	HOSE GUIDE W/ CLAMP BOLT - 1/2" X 7 1/2" LG. GR. 5 LOCK WASHER - 1/2" NUT-1/2"	12 LBS. N/A N/A N/A
9	OX-7ME	DRAW BAR - HITCH, HVY.	250 LBS.
10	OX-138 CS588-5 LW58 N58	HITCH JACK -5000 LBS. (INC. MOUNTING PARTS) BOLT - 5/8" X 8" LG. GR. 5 LOCK WASHER - 5/8" NUT - 5/8"	17.0 LBS. N/A N/A N/A
11	OX-8 OX-8C	TONGUE SINGLE, HVY. TONGUE CLEVIS, HVY.	24 LBS. 23.5 LBS.
12	OX-126 LW114 N114	BOLT - HITCH TONGUE LOCK WASHER - 1 1/4" NUT - 1 1/4"	3.7 LBS. N/A N/A

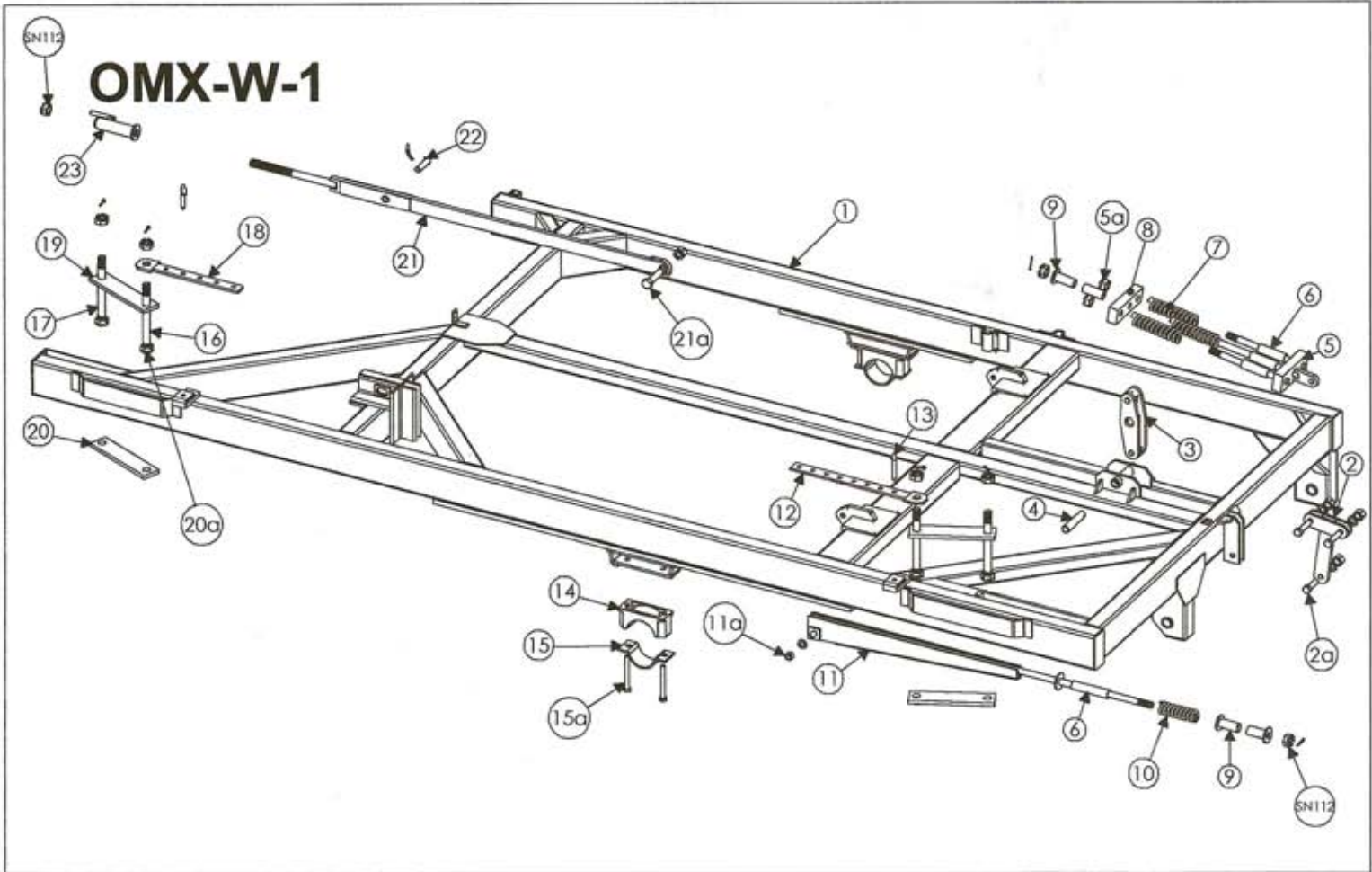

MAIN FRAME ASSEMBLY

REF#	PART #	DESCRIPTION	WT/LB.
1	OMX-W-1	MAIN FRAME - 86" (WING DISC)	
2	ON-12	HAMMER - LEVELING	26.3 LBS.
2a	CS1312-5 LN1	BOLT - 1" X 3 1/2" LG. GR. 5 LOCK NUT - 1"	
3	ON-18	LEVER - SWIVEL	26.3 LBS.
4	ON-134	PIN - ROCKER	4.0 LBS
5	ONX-13	LEVEING ROD - DUAL SPRING	64.0 LBS
5a	SN-112	SLOTTED NUT - 1 1/2" COTTER PIN	
6	ON-150	TUBE CRUSH SPRING	2.5 LBS.
7	OX-14 (ON -14)	LEVELING SPRING	7.0 LBS.
8	OX-50	BLOCK - RETAINER	20.0 LBS.
9	OX-15	TUBE FLANGE	1.8 LBS.

REF#	PART #	DESCRIPTION	WT/LB.
10	OX-14S	SPRING - LEVEING	11.7 LBS.
11	OMX-22	LEVEING ROD - REAR	67.0 LBS.
11a	CS114-5	BOLT - 1 1/4" X 4" LG. GR. 5	1.2 LBS.
	LN1	LOCK NUT - 1 1/4"	0.1 LBS.
12	OX-64	SET BAR - ANGLE, FRNT. GNG.	11.2 LBS.
13	ON-67	PIN - J	2.0 LBS
14	ON-68	BLOCK AXLE MNTG.	29.1 LBS.
15	ON-69	CAP - AXLE MTG.	9.0 LBS.
15a	CS78712-5	BOLT - 7/8" X 7 1/2" LG. GR. 5	1.5 LBS.
	LW78	LOCK WASHER - 7/8"	N/A
	N78	NUT - 7/8"	N/A
16	ON-70	GANG FRAME BOLT (LONG) 2 PER DISC	10.0 LBS.
17	ON-71	GANG FRAME BOLT (SHORT) 6 PER DISC	10.1 LBS.
18	OX-66	SET BAR - ANGLE, REAR GNG.	9.0 LBS.
19	OW-1-21	STRAP - GANG TO FRAME, TOP	13.0 LBS.
20	OW-1-22	STRAP - GANG TO FRAME BOTTOM	14.0 LBS.
20a	SN112	SLOTTED NUT - 1 1/2"	0.8 LBS.
21	OMX-58	ROD - DEPTH CONTROL	79.9 LBS.
21a	CS114-5	BOLT - 1 1/4" X 5" LG. GR.5	2.3 LBS.
	LW114	LOCK WASHER - 1 1/4"	N/A
	N114	NUT - 1 1/4"	N/A
22	OX-140	PIN - TRANSPORT	3.9 LBS.
	BLD-33	KLICK PIN	0.2 LBS.
23	ON-60	CRANK DEPTH CONTROL	5.0 LBS
	SN112	SLOTTED NUT - 1 1/2"	0.8 LBS

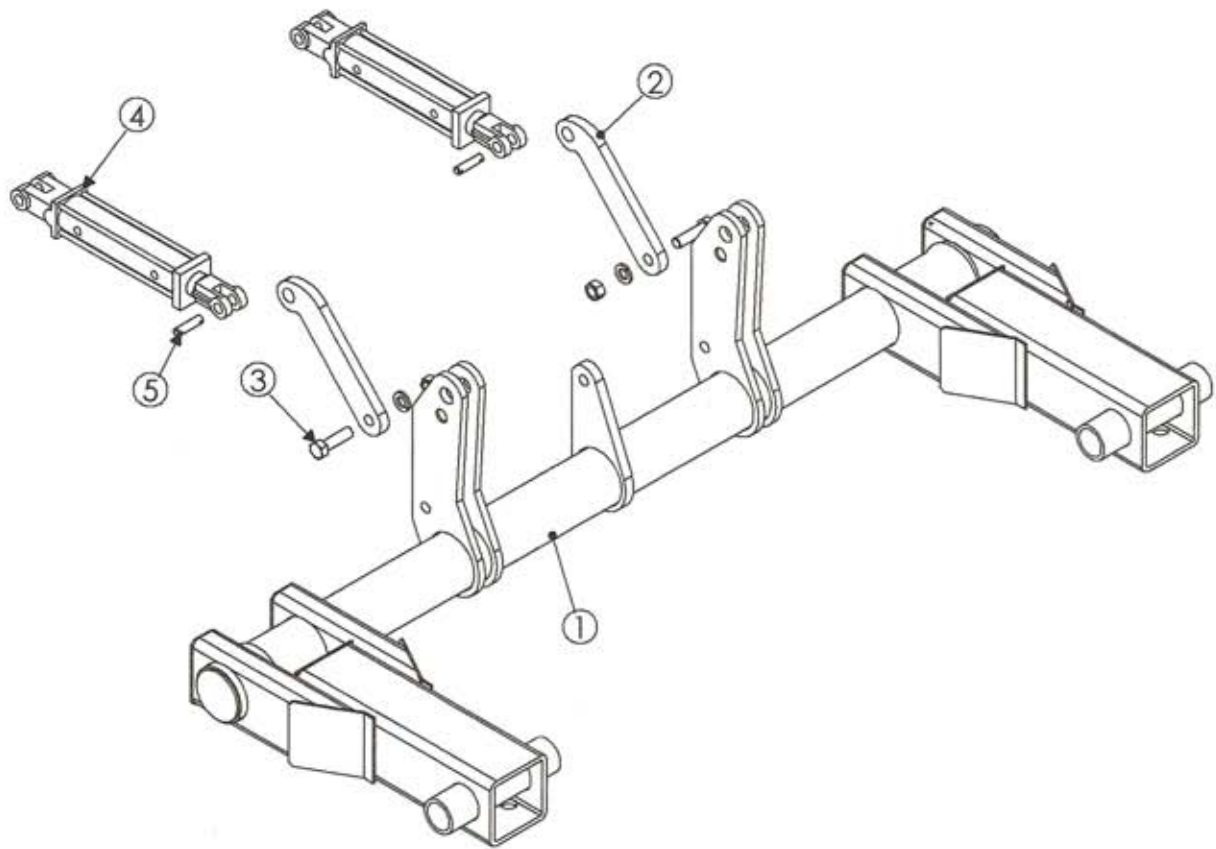

AXLE ASSEMBLY

REF#	PART #	DESCRIPTION	WT/LB.
1	OM-25	AXLE	459.0 LBS.
2	ON-56	AXLE SCISSOR	14.0 LBS.
3	CS1312-5	BOLT - 1" NC. X 3 1/2" LG. GR.5	1.1 LBS.
	LW1	LOCK WASHER - 1"	N/A
	N1	NUT - 1"	N/A
4	ON-53	HYD. CYLINDER 4" BORE X 16" STR.	57.0 LBS.
5	ON-55	PIN W RETAINER (HYD. CYL.)	0.9 LBS.

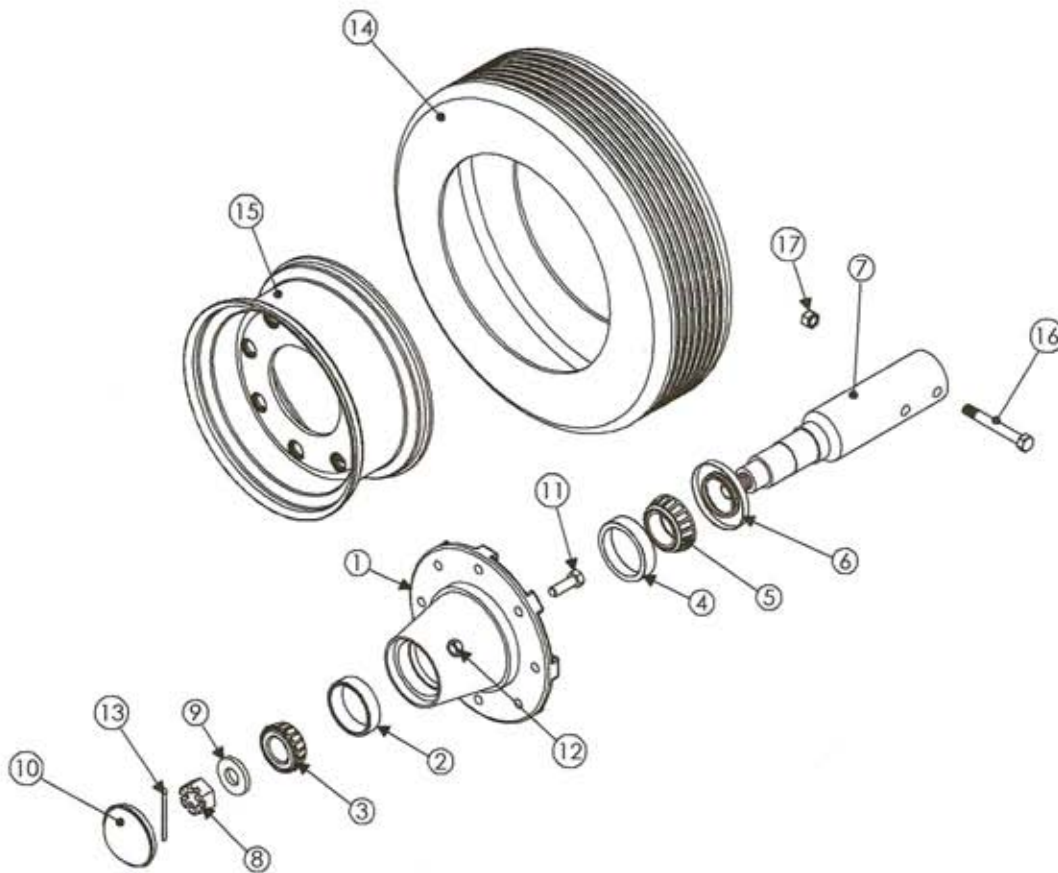

SPINDLE ASSEMBLY

1	RPO-163	HUB W/ CUPS	10.0 LBS.
2	RPO-147	BEARING CUP - OUTER	0.1 LBS.
3	RPO-148	BEARING CONE - OUTER	0.3 LBS.
4	RPO-145	BEARING CUP - INNER	0.2 LBS.
5	RPO-146	BEARING CONE - INNER	0.4 LBS.
6	RPO-144	OUTER SEAL	0.1 LBS.
7	FX-518	SLIP IN SPINDLE	9.0 LBS.
8	SN78F	SLOTTED NUT	0.1 LBS.
9	RPO-159	SPINDLE WASHER	0.01 LBS.
10	RPO-151	DUST CAP	0.2 LBS.
11	RPO-168	LUG BOLT - (1/2" NG X 1" LG.)	0.1 LBS.
12	N916-F	NUT 9/16"	N/A
13	CP3162	COTTER PIN 3/16" X 2" LG.	N/A
14	FX-534	TIRE - 7.60-15, RIB 6 PLY.	24.0 LBS.
15	FX-533	WHEEL 15 X 6, 8 (1/2)	23.0 LBS.
16	CS12412-5	BOLT - 1/2" NC. X 4 1/2" GR.	N/A
17	LN-12	LOCK NUT - 1/2"	N/A

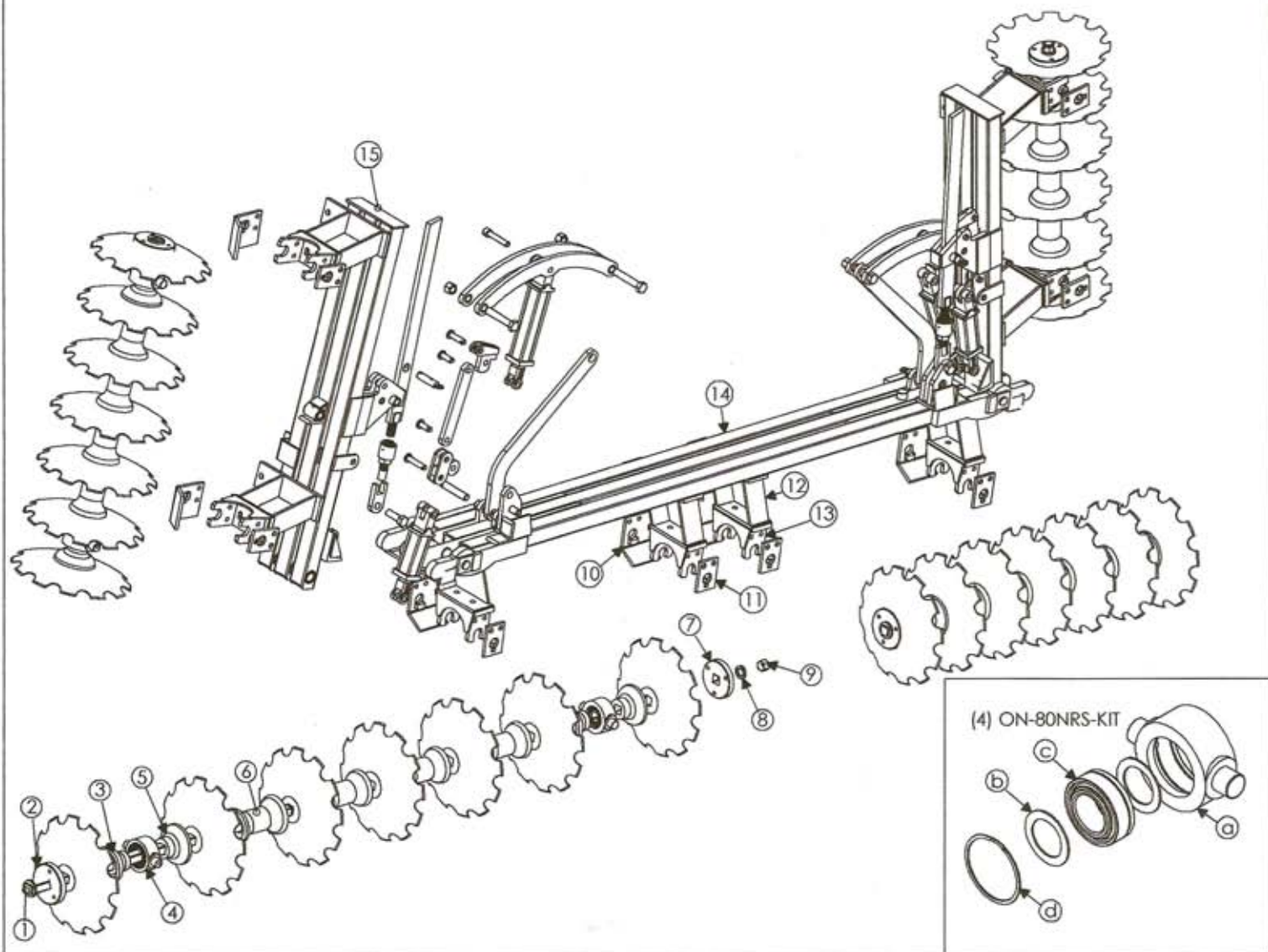

GANG ASSEMBLY

REF#	PART #	DESCRIPTION	WT/LB.
1	ON-105	GANG ROD - 1 1/2" SQ. 4 BLD. 9" SPC.	21.1 LBS.
	ON-106	GANG ROD - 1 1/2" SQ. 5 BLD. 9" SPC.	26.9 LBS.
	ON-107	GANG ROD - 1 1/2" SQ. 6 BLD. 9" SPC.	33.1 LBS.
	ON-108	GANG ROD - 1 1/2" SQ. 7 BLD. 9" SPC.	38.6 LBS.
	ON-109	GANG ROD - 1 1/2" SQ. 8 BLD. 9" SPC.	44.8 LBS.
	ON-110	GANG ROD - 1 1/2" SQ. 9 BLD. 9" SPC.	51.1 LBS.
	ON-111	GANG ROD - 1 1/2" SQ. 4 BLD. 10 1/2" SPC.	23.3 LBS.
	ON-112	GANG ROD - 1 1/2" SQ. 5 BLD. 10 1/2" SPC.	30.3 LBS.
	ON-113	GANG ROD - 1 1/2" SQ. 6 BLD. 10 1/2" SPC.	37.3 LBS.
	ON-114	GANG ROD - 1 1/2" SQ. 7 BLD. 10 1/2" SPC.	44.1 LBS.
	ON-115	GANG ROD - 1 1/2" SQ. 8 BLD. 10 1/2" SPC.	50.5 LBS.
	ON-116	GANG ROD - 1 1/2" SQ. 9 BLD. 10 1/2" SPC.	57.0 LBS.
	ON-118	GANG ROD - 1 1/2" SQ. 10 BLD. 10 1/2" SPC.	64.0 LBS.
ON-119	GANG ROD - 1 1/2" SQ. 11 BLD. 10 1/2" SPC.	71.0 LBS.	
2	JXE-19	EXT. WASHER - CCV, 1 1/2" SQ.	8.0 LBS.

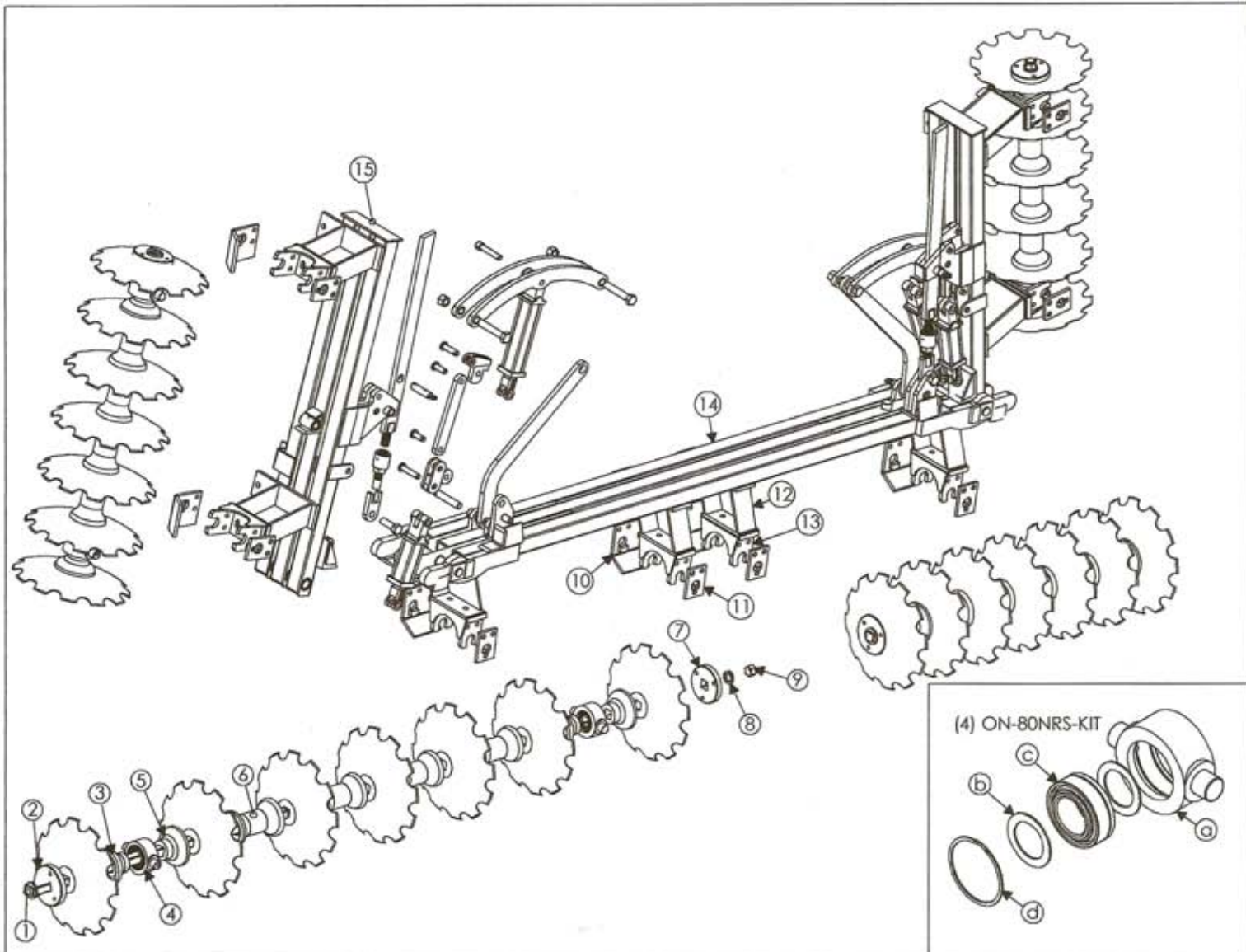

GANG ASSEMBLY

REF#	PART #	DESCRIPTION	WT/LB.
1	ON-105	GANG ROD - 1 1/2" SQ. 4 BLD. 9" SPC.	21.1 LBS.
	ON-106	GANG ROD - 1 1/2" SQ. 5 BLD. 9" SPC.	26.9 LBS.
	ON-107	GANG ROD - 1 1/2" SQ. 6 BLD. 9" SPC.	33.1 LBS.
	ON-108	GANG ROD - 1 1/2" SQ. 7 BLD. 9" SPC.	38.6 LBS.
	ON-109	GANG ROD - 1 1/2" SQ. 8 BLD. 9" SPC.	44.8 LBS.
	ON-110	GANG ROD - 1 1/2" SQ. 9 BLD. 9" SPC.	51.1 LBS.
	ON-111	GANG ROD - 1 1/2" SQ. 4 BLD. 10 1/2" SPC.	23.3 LBS.
	ON-112	GANG ROD - 1 1/2" SQ. 5 BLD. 10 1/2" SPC.	30.3 LBS.
	ON-113	GANG ROD - 1 1/2" SQ. 6 BLD. 10 1/2" SPC.	37.3 LBS.
	ON-114	GANG ROD - 1 1/2" SQ. 7 BLD. 10 1/2" SPC.	44.1 LBS.
	ON-115	GANG ROD - 1 1/2" SQ. 8 BLD. 10 1/2" SPC.	50.5 LBS.
	ON-116	GANG ROD - 1 1/2" SQ. 9 BLD. 10 1/2" SPC.	57.0 LBS.
	ON-118	GANG ROD - 1 1/2" SQ. 10 BLD. 10 1/2" SPC.	64.0 LBS.
	ON-119	GANG ROD - 1 1/2" SQ. 11 BLD. 10 1/2" SPC.	71.0 LBS.
2	JXE-19	EXT. WASHER - CCV, 1 1/2" SQ.	8.0 LBS.

REF#	PART #	DESCRIPTION	WT/LB.
3	OF-84-SS	HALF SPOOL - CVX, 1 1/2" SQ. 9" SPC.	8.3 LBS.
	OF-84-S-F	HALF SPOOL - CVX, 1 1/2" SQ. 9" SPC. (STEEL FAB)	N/A
	OF-84L-SS	HALF SPOOL - CVX, 1 1/2" SQ. 10 1/2" SPC.	12.6 LBS.
	OF-84L-SS-F	HALF SPOOL - CVX, 1 1/2" SQ. 10 1/2" SPC. (STEEL FAB)	N/A
4	ON-80NRS-KIT	BEARING ASSY. - 1 1/2" SQ. NON-RELUBE SHIELDED	14.0 LBS.
a	ON-138	BRG. HSG. 1 1/2" SQ. (INCLUDES SHIELDS)	8.2 LBS.
b	ON-136	BRG. SHIELDS	0.5 LBS.
c	RPO-103I	BRG. GANG, 1 1/2" SQ. NR, IMPORT	3.2 LBS.
d	RPO-99	RETAINING RING	0.1 LBS.
5	OF-83-SS	HALF SPOOL - CCV, 1 1/2" SQ. 9" & 10 1/2" SPC.	N/A
	OF-83-SS-F	HALF SPOOL - CCV, 1 1/2" SQ. 9" & 10 1/2" SPC. (STEEL FAB)	N/A
6	OF-9	SPACER SPOOL 1 1/2" SQ., 9" SPC.	23.8 LBS.
	OF-9-F	SPACER SPOOL 1 1/2" SQ., 9" SPC. (STEEL FAB)	N/A
7	JXE-19	EXT. WASHER - CVX, 1 1/2" SQ.	8.0 LBS.
8	LW112	LOCK WASHER - 1 1/2"	0.2 LBS.
9	SN112	SLOTTED NUT - 1 1/2"	0.8 LBS.
10	ON-222F	BRG. CAP W/GUARD 1 1/2" SQ. (FRONT GANG)	7.6 LBS.
	ON-222R	BRG. CAP W/GUARD 1 1/2" SQ. (REAR GANG)	7.6 LBS.
	CS58134-5	BOLT - 5/8" NC. X 1 3/4" LG. GR. 5	0.3 LBS.
	LW58	LOCK WASHER - 5/8"	0.1 LBS.
	N58	NUT - 5/8"	
11	ON-223	BRG. STRAP CAP - 1 1/2" SQ. (SHORT)	2.1 LBS.
	CS58214	BOLT - 5/8" X 2 1/4" LG. GR. 5	0.5 LBS.
	LW58	LOCK WASHER - 5/8"	0.3 LBS.
	N58	NUT - 5/8"	0.1 LBS.
12	ON-225	BRACKET - BRG., FRONT	45.0 LBS.
	ON-226	BRACKET - BRG., REAR	45.0 LBS.
13	ON-224	BRG. HOLDER - ADJ. - 1 1/2" SQ.	10.1 LBS.
14	MW1-01F	FRONT GANG - CENTER SECTION 9" SPC.	1125.0 LBS.
	MW1-01R	REAR GANG - CENTER SECTION 9" SPC.	1125.0 LBS.

REF#	PART #	DESCRIPTION	WT/LB.
15	MW1-04B-RF	WING - RIGHT HAND FRONT 4 BLD. 9" SPC.	N/A
	MW1-04B-LR	WING - LEFT HAND REAR 4 BLD.9" SPC.	N/A
	MW1-02	WING - RIGHT HAND FRONT 5 BLD. 9" SPC.	N/A
	MW1-03	WING - LEFT HAND FRONT 5 BLD. 9" SPC.	N/A
	MW1-04	WING - RIGHT HAND REAR 5 BLD. 9" SPC.	N/A
	MW1-05	WING - LEFT HAND REAR 5 BLD. 9" SPC.	N/A
	MW1-06B-RF	WING - RIGHT HAND FRONT 6 BLD. 9" SPC.	N/A
	MW1-06B-LF	WING - LEFT HAND FRONT 6 BLD. 9" SPC.	N/A
	MW1-06B-RR	WING - RIGHT HAND REAR 6 BLD. 9" SPC.	N/A
	MW1-06B-LR	WING - LEFT HAND REAR 6 BLD. 9" SPC.	N/A
	MW1-07B-RF	WING - RIGHT HAND FRONT 7BLD. 9" SPC.	N/A
	MW1-07B-LF	WING - LEFT HAND FRONT 7 BLD. 9" SPC.	N/A
	MW1-07B-RR	WING - RIGHT HAND REAR 7 BLD. 9" SPC.	N/A
	MW1-07B-LR	WING - LEFT HAND REAR 7 BLD. 9" SPC.	N/A
	MW1-08B-RF	WING - RIGHT HAND FRONT 8 BLD. 9" SPC.	N/A
	MW1-08B-LF	WING - LEFT HAND FRONT 8 BLD. 9" SPC.	N/A
	MW1-08B-RR	WING - RIGHT HAND REAR 8 BLD. 9" SPC.	N/A
	MW1-08B-LR	WING - LEFT HAND REAR 8 BLD.9" SPC.	N/A
	MW1-09B-RF	WING - RIGHT HAND FRONT 9 BLD. 9" SPC.	N/A
	MW1-09B-LF	WING - LEFT HAND FRONT 9 BLD. 9" SPC.	N/A
	MW1-09B-RR	WING - RIGHT HAND REAR 9 BLD. 9" SPC.	N/A
	MW1-09B-LR	WING - LEFT HAND REAR 9 BLD. 9" SPC.	N/A
	OM2-01F	FRONT GANG - CENTER SECTION - 101/2" SPC.	1456.0 LBS.
	OM2-01R	REAR GANG - CENTER SECTION - 101/2" SPC.	1456.0 LBS.
	OM2-28	WING - RIGHT HAND FRONT , 4 BLD. 10 1/2" SPC.	N/A
	OM2-29	WING - LEFT HAND REAR , 4 BLD. 10 1/2" SPC.	N/A
	OM2-30	WING - RIGHT HAND FRONT, 5 BLD. 10 1/2" SPC.	926.0 LBS
	OM2-31	WING - LEFT HAND FRONT, 5 BLD. 10 1/2" SPC.	926.0 LBS.
	OM2-32	WING - RIGHT HAND REAR, 5 BLD. 10 1/2" SPC.	N/A
	OM2-33	WING - LEFT HAND REAR, 5 BLD. 10 1/2" SPC.	N/A
	OM2-34	WING - RIGHT HAND FRONT, 6 BLD. 10 1/2" SPC.	N/A
	OM2-35	WING - LEFT HAND FRONT, 6 BLD. 10 1/2" SPC.	N/A
	OM2-36	WING - RIGHT HAND REAR, 6 BLD. 10 1/2" SPC.	N/A
	OM2-37	WING - LEFT HAND REAR, 6 BLD. 10 1/2" SPC.	N/A
	OM2-38	WING - RIGHT HAND FRONT, 7 BLD. 10 1/2" SPC.	N/A
	OM2-39	WING - LEFT HAND FRONT, 7 BLD. 10 1/2" SPC.	N/A
	OM2-40	WING - RIGHT HAND REAR, 7 BLD. 10 1/2" SPC.	N/A
	OM2-41	WING - LEFT HAND REAR, 7 BLD. 10 1/2" SPC.	N/A
	OM2-42	WING - RIGHT HAND FRONT, 8 BLD. 10 1/2" SPC.	N/A
	OM2-43	WING - LEFT HAND FRONT, 8 BLD. 10 1/2" SPC.	N/A
	OM2-44	WING - RIGHT HAND REAR, 7 BLD. 10 1/2" SPC.	N/A
	OM2-45	WING - LEFT HAND REAR, 8 BLD. 10 1/2" SPC.	N/A

REF#	PART #	DESCRIPTION	WT/LB.
9	CS114412-5	BOLT - 1 1/4" NC. X 4 1/2" LG. GR. 5	
	LW114	LOCK WASHER - 1 1/4"	0.1 LBS.
	N114	NUT - 1 1/4"	0.6 LBS.
10	MW1-07	BOLT - TURN BUCKLE L.H. THRDS.	4.5 LBS
11	JN112	JAM NUT - 1 1/2"	0.6 LBS.
	7000	GREASE ZERK	
12	MW1-08	TURN BUCKLE - BODY	4.2 LBS.
13	MW1-06	BOLT - TURN BUCKLE R.H. THRDS.	26.5 LBS.
14	MW1-25	PIN - TRANSPORT W/CABLE	N/A
15	MW1-09	PIN - HYD. CYL. TO PIVOT ARMS	1.9 LBS.
	CP5163	COTTER PIN - 5/16" X 3" LG.	N/A
16	MW1-11	PIVOT - ARM LEFT HAND	33.3 LBS.
17	CS114712-5	BOLT - 1 1/4" NC. X 7 1/2" LG. GR. 5	3.2 LBS.
18	MW1-12	PIVOT - ARM RIGHT HAND	33.3 LBS.
19	JJ-90	HYD. CYLINDER - 3" DIA. X 12" STRK. (W/PINS)	30.0 LBS.
20	MW1-37	HYD. CYLINDER - 2 1/4" DIA. X 4" STRK. (LOCK CYL.)	N/A
21	MW1-10	PIN -WING PIVOT	12.1 LBS
22	1641	GREASE ZERK -1/4-28	N/A

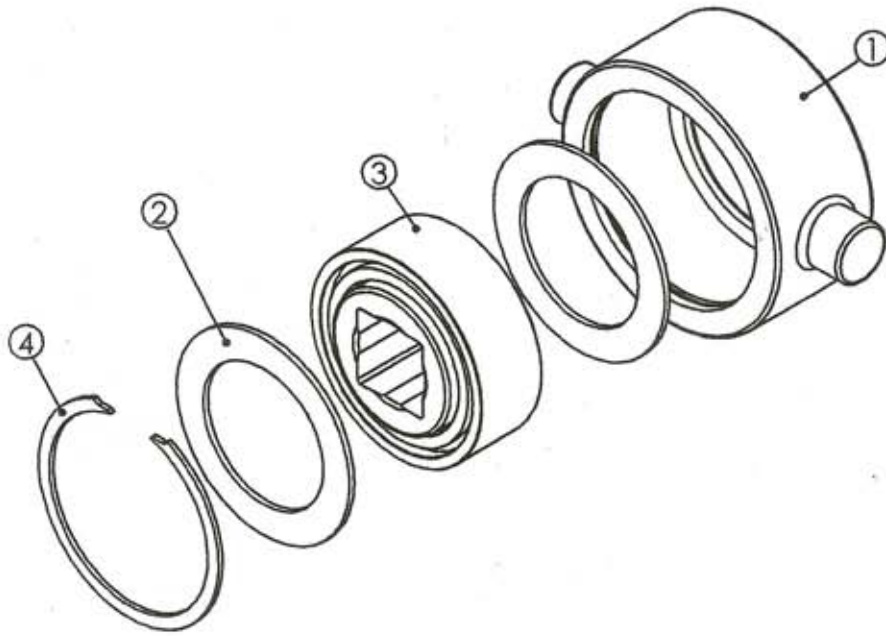

ON-80NRS-KIT

REF#	PART #	DESCRIPTION	WT/LB.
1	ON-138	BRG. - HOUSING	
2	ON-136	BRG. - SHIELDS	
3	RPO-103I	BRG. 1 1/2" SQ. RELUBE (W211PP5)	
4	RP0-99	SNAP RING	

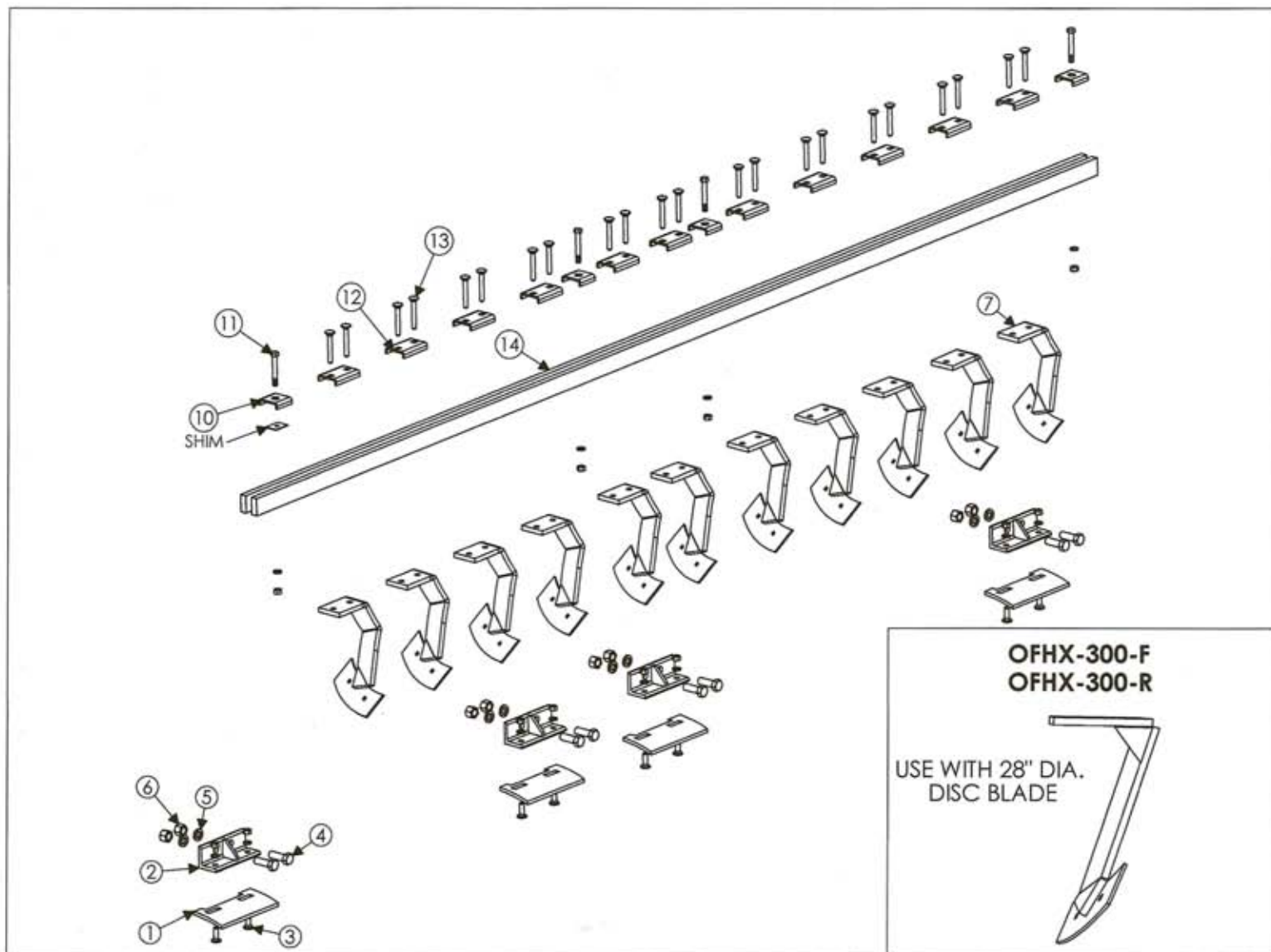

CLEANER ASSEMBLY

REF#	PART #	DESCRIPTION	WT/LB.
1	ON-157	THRASH PLATE - 9" SPACING	5.0 LBS.
	FXSL-230	THRASH PLATE - 10 1/2" SPACING	5.8 LBS.
2	ON-158	HOLDER - TRASH PLATE (ON-157)	4.2 LBS.
	FXSL-229	HOLDER - TRASH PLATE (FXSL-230)	4.0 LBS.
3	CB12112-5	CARRIAGE BOLT - 1/2" NC. X 1 1/2" LG. GR. 5	0.2 LBS.
	LW12	LOCK WASHER - 1/2"	0.1 LBS.
	N12	NUT - 1/2"	0.1 LBS.
4	CS58214-5	BOLT - 5/8" NC. X 2 1/4" LG. GR. 5	0.3 LBS.
5	LW58	LOCK WASHER - 5/8"	0.1 LBS.
6	N58	NUT - 5/8"	0.1 LBS.
7	OFH-300-F	CLEANER ARM - FRONT HVY. DTY.	N/A
	OFHX-300-F	CLEANER ARM - FRONT (WHEN USING 28" DISC BLADES ONLY)	N/A
	OFH-300-R	CLEANER ARM - REAR HVY. DTY.	N/A
	OFHX-300-R	CLEANER ARM - REAR (WHEN USING 28" DISC BLADES ONLY)	N/A
8	OF-309	BLADE CLEANER	2.0 LBS.

REF#	PART #	DESCRIPTION	WT/LB.
9	CB381-5	CARRIGE BOLT - 3/8" NC. X 1" LG. GR. 5	N/A
	LW38	LOCK WASHER - 3/8"	N/A
	N38	NUT - 3/8"	N/A
10	OF-307-W	CAP - CLEANER BAR W/SHIM (ON CENTER GANGS ONLY)	N/A
	OF-307	CAP - CLEANER BAR - STANDARD	N/A
11	CS34412-5	BOLT - 3/4" NC. X 4 1/2" LG. GR. 5	N/A
	LW34	LOCK WASHER - 3/4"	N/A
	N34	NUT - 3/4"	N/A
12	OF-305	CAP CLEANER ARM	0.5 LBS.
13	CB12312-5	CARRIGE BOLT - 1/2" NC. X 3 1/2" LG. GR. 5	N/A
	LW12	LOCK WASHER - 1/2"	N/A
	N12	NUT - 1/2"	N/A
14	MWC-1	CLEANER BAR - CENTER GANG (WING DISC) 133" LG.	N/A
	MWC-4	CLEANER BAR - 4 BLADE , 9" SPC. 39" LG.	N/A
	MWC-5	CLEANER BAR - 5 BLADE , 9" SPC.48" LG.	N/A
	MWC-6	CLEANER BAR - 6 BLADE , 9" SPC. 57" LG.	N/A
	MWC-7	CLEANER BAR -7 BLADE , 9" SPC. 66" LG.	N/A
	MWC-8	CLEANER BAR - 8 BLADE , 9" SPC. 76" LG.	N/A
	MWC-9	CLEANER BAR - 9 BLADE , 9" SPC. 85" LG.	N/A
	OMC-4	CLEANER BAR - 4 BLADE , 10 1/2" SPC. 44" LG.	N/A
	ONC-5	CLEANER BAR - 5 BLADE , 10 1/2" SPC. 55" LG.	N/A
	OMC-6	CLEANER BAR -6 BLADE , 10 1/2" SPC. 66" LG.	N/A
	OMC-7	CLEANER BAR -7 BLADE , 10 1/2" SPC. 77" LG.	N/A
	OMC-8	CLEANER BAR -8 BLADE , 10 1/2" SPC. 88" LG.	N/A
OPTIONAL CLEANER ASSY.			
	OFH-300A-F	CLEANER ASSY. - HVY. DTY.	N/A
	OFH-300A-R	CLEANER ASSY. - HVY. DTY.	N/A
	OFHX-300A-F	CLEANER ASSY. - HVY. DTY. (USE W/28" D BLD.)	N/A
	OFHX-300A-R	CLEANER ASSY. - HVY. DTY. (USE W/28" D BLD.)	N/A

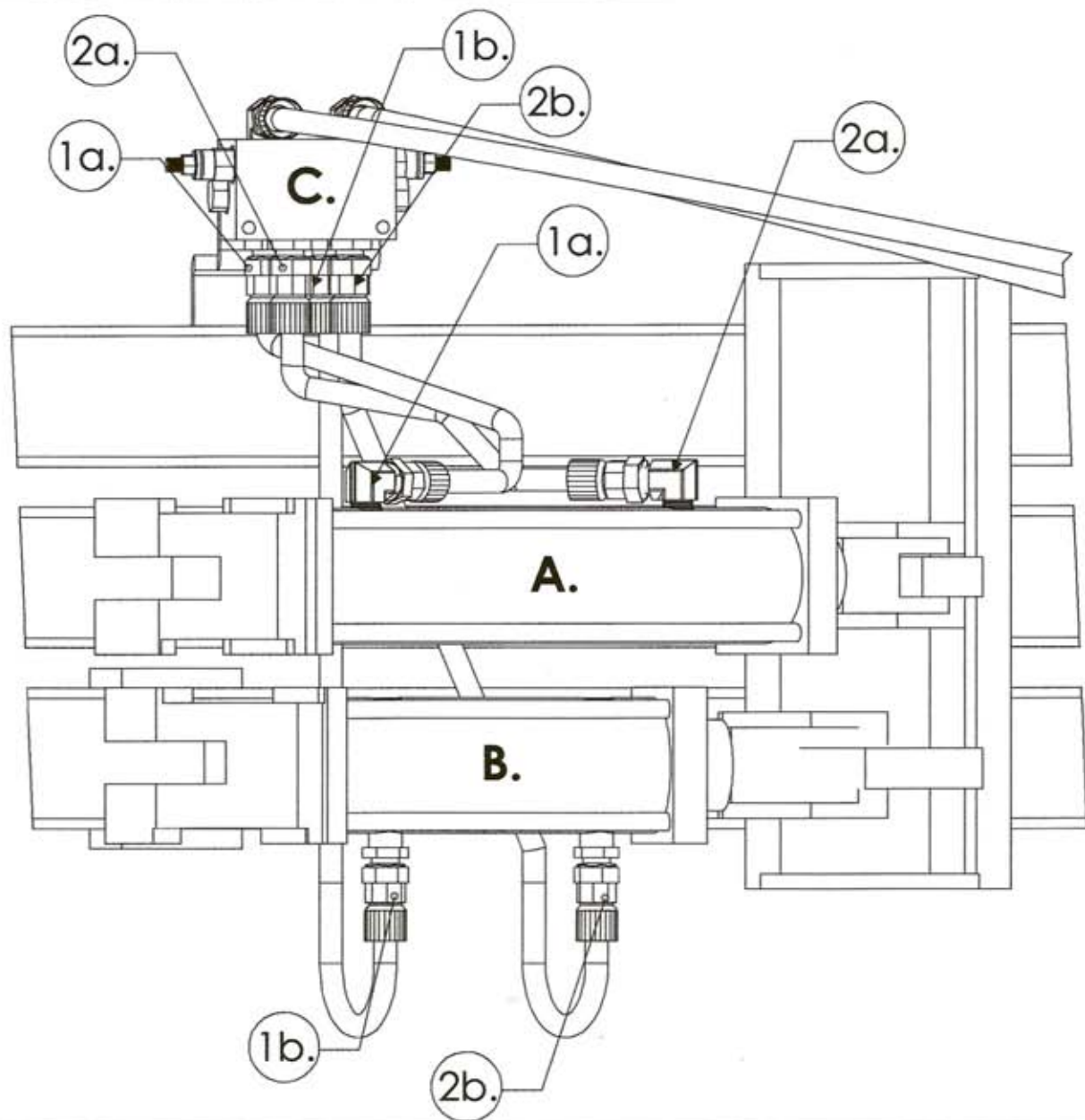

REF#	PART #	DESCRIPTION	WT/LB.
A.	JJ-90	HYD. CYLINDER 3" DIA. X 12" STRK. (W/PINS)	
1a.	HYDRAULIC HOSE	CONNECT BOTTOM LEFT OF SEQUENCING VALVE C. TO LEFT SIDE OF HYRAULIC A.	
2a.	HYDRAULIC HOSE	CONNECT TOP LEFT OF SEQUENCING VALVE C. TO RIGHT SIDE OF HYRAULIC A	
B.	MW-1-37	HYD. CYLINDER 2 1/4" DIA. X 4" STRK. (LOCK CYL.)	
1b.	HYDRAULIC HOSE	CONNECT BOTTOM RIGHT OF SEQUENCING VALVE C. TO LEFT SIDE OF HYRAULIC B.	
2b.	HYDRAULIC HOSE	CONNECT TOP RIGHT OF SEQUENCING VALVE C. TO RIGHT OF HYRAULIC B.	
C.	MW1-97	SEQUENCING VALVE	

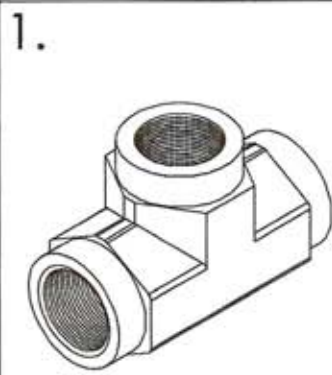

FPT-8



FP-FP90-8-8

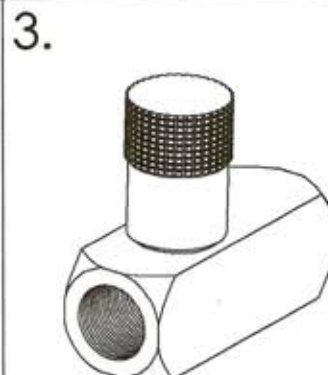

PF800-S

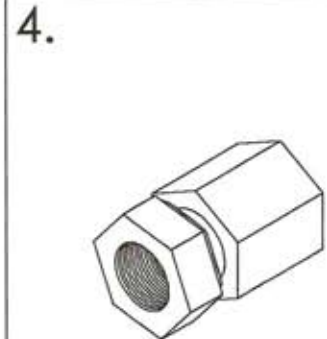

FP-FPX-8-8

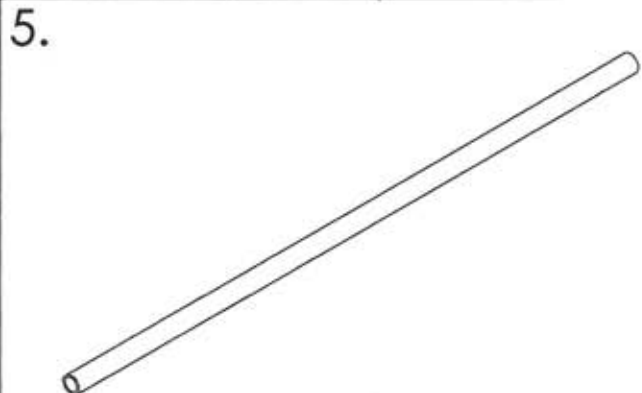

MW1-38 THROUGH MW1-49

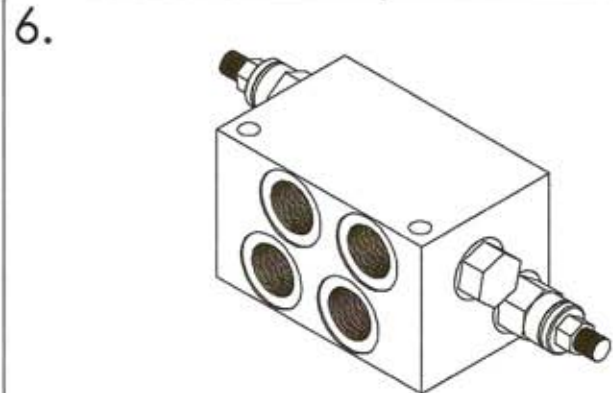

MW1-97

HYDRAULIC ATTACHMENTS

REF#	PART #	DESCRIPTION	WT/LB.
1	FPT-8	FEMALE PIPE TEE - 1/2" FP - 1/2" FP - 1/2" FP	0.5 LBS.
2	FP-FP90-8-8	FEMALE PIPE - FEMALE PIPE 90	0.5 LBS.
3	PF800-S	FLOW VALVE CONTROL	1.5 LBS.
4	FP-FPX-8-8	FEMALE PIPE - FEMALE PIPE SWVEL - STRAIGHT	0.5 LBS.
5	MW1-38	HYDRAULIC PIPE - WING FOLD 17 1/2" LG.	
	MW1-39	HYDRAULIC PIPE - WING FOLD 19 1/2" LG.	
	MW1-40	HYDRAULIC PIPE - WING FOLD 20" LG.	
	MW1-41	HYDRAULIC PIPE - WING FOLD 23" LG.	
	MW1-42	HYDRAULIC PIPE - WING FOLD 34 1/2" LG.	
	MW1-43	HYDRAULIC PIPE - WING FOLD 36 1/2" LG.	
	MW1-44	HYDRAULIC PIPE - WING FOLD 37 1/2" LG.	
	MW1-45	HYDRAULIC PIPE - WING FOLD 42" LG.	
	MW1-46	HYDRAULIC PIPE - WING FOLD 45" LG.	
	MW1-47	HYDRAULIC PIPE - WING FOLD 74" LG.	
	MW1-48	HYDRAULIC PIPE - WING FOLD 84" LG.	
MW1-49	HYDRAULIC PIPE - WING FOLD 111" LG.		
6	MW1-97	SEQUENCING VALVE	

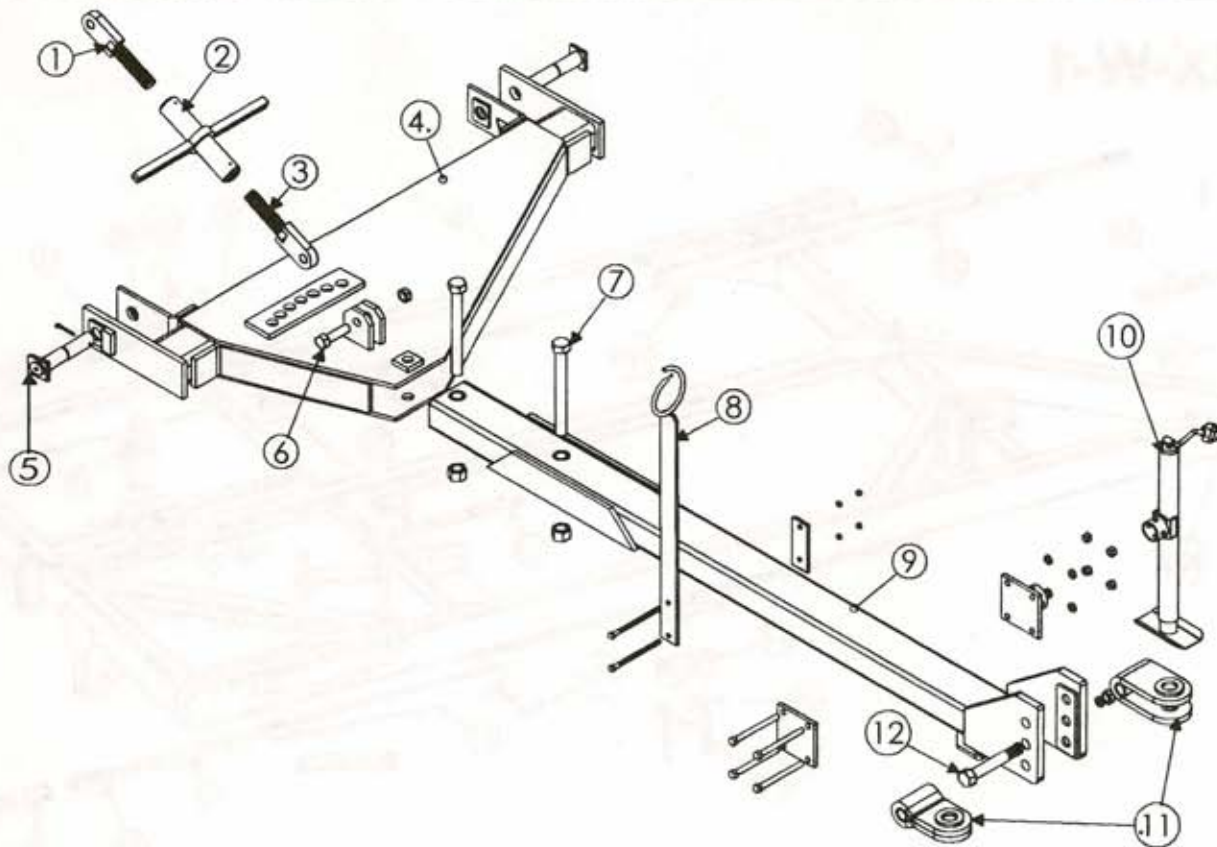

HITCH ASSEMBLY

REF#	PART #	DESCRIPTION	WT/LB.
1	OX-9	BOLT - TURNBUCKLE, R.H. THRD.	6.5 LBS.
2	OX-10	BODY - TURNBUCKLE	14.75 LBS.
3	OX-11	BOLT - TURNBUCKLE, L.H. THRD.	6.5 LBS.
4	OM-5	CROSS MEMBER - HITCH	490.0 LBS.
5	ON-61	PIN - HITCH	5.5 LBS.
6	CS1312-5 LN1	BOLT - 1" X 3 1/2" LG. GR. 5 LOCK NUT - 1"	1.1 LBS. .1 LBS.
7	SC11412-8 N114	BOLT - 1 1/4" X 12" LG. GR. 8 NUT-1 1/4"	N/A N/A
8	ON-139 CS12712-5 LW12 N12	HOSE GUIDE W/ CLAMP BOLT - 1/2" X 7 1/2" LG. GR. 5 LOCK WASHER - 1/2" NUT-1/2"	12 LBS. N/A N/A N/A
9	OX-7ME	DRAW BAR - HITCH, HVY.	250 LBS.
10	OX-138 CS588-5 LW58 N58	HITCH JACK -5000 LBS. (INC. MOUNTING PARTS) BOLT - 5/8" X 8" LG. GR. 5 LOCK WASHER - 5/8" NUT - 5/8"	17.0 LBS. N/A N/A N/A
11	OX-8 OX-8C	TONGUE SINGLE, HVY. TONGUE CLEVIS, HVY.	24 LBS. 23.5 LBS.
12	OX-126 LW114 N114	BOLT - HITCH TONGUE LOCK WASHER - 1 1/4" NUT - 1 1/4"	3.7 LBS. N/A N/A

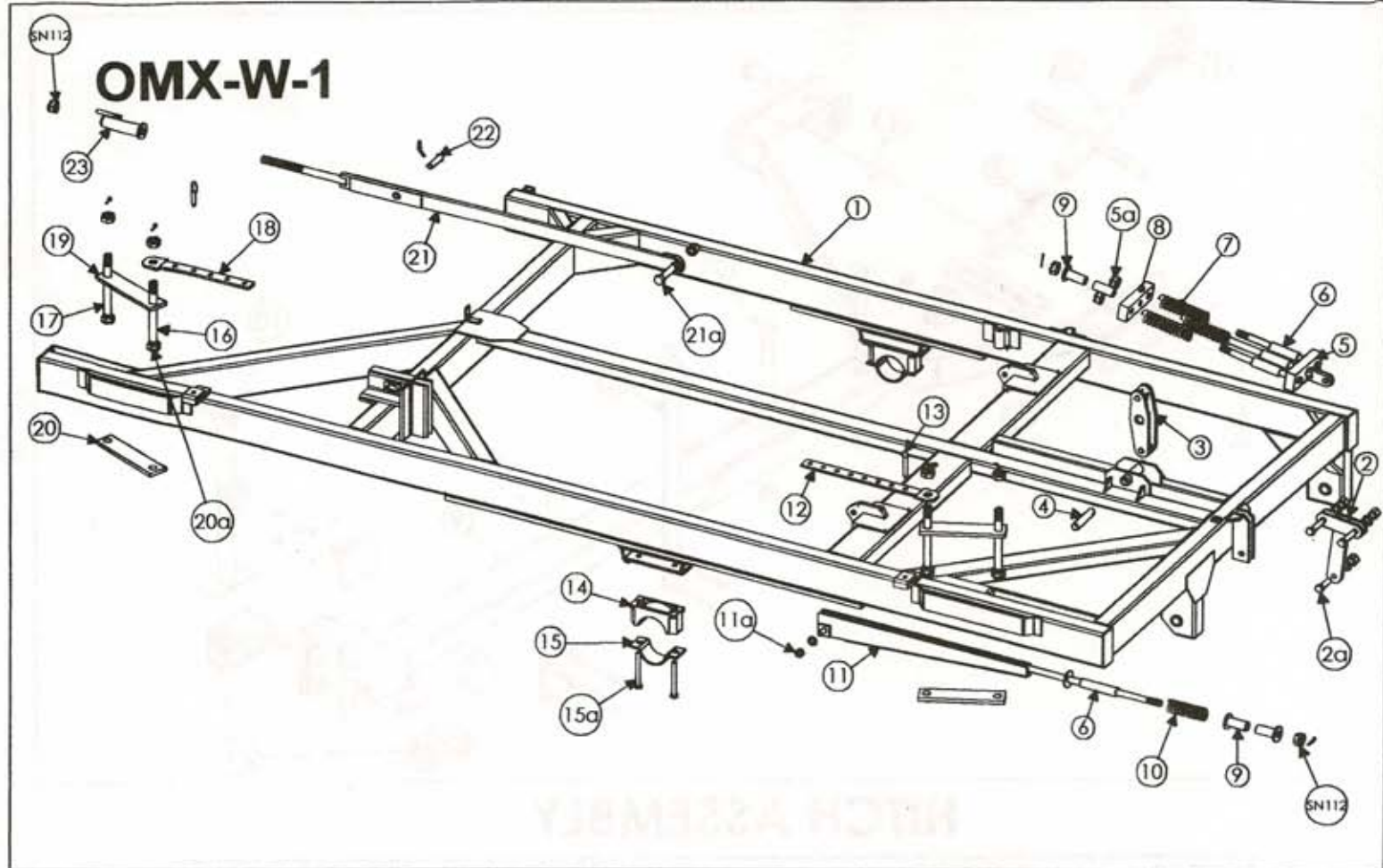

MAIN FRAME ASSEMBLY

REF#	PART #	DESCRIPTION	WT/LB.
1	OMX-W-1	MAIN FRAME - 86" (WING DISC)	
2	ON-12	HAMMER - LEVELING	26.3 LBS.
2a	CS1312-5 LN1	BOLT - 1" X 3 1/2" LG. GR. 5 LOCK NUT - 1"	
3	ON-18	LEVER - SWIVEL	26.3 LBS.
4	ON-134	PIN - ROCKER	4.0 LBS
5	ONX-13	LEVELING ROD - DUAL SPRING	64.0 LBS
5a	SN-112	SLOTTED NUT - 1 1/2" COTTER PIN	
6	ON-150	TUBE CRUSH SPRING	2.5 LBS.
7	OX-14 (ON -14)	LEVELING SPRING	7.0 LBS.
8	OX-50	BLOCK - RETAINER	20.0 LBS.
9	OX-15	TUBE FLANGE	1.8 LBS.

REF#	PART #	DESCRIPTION	WT/LB.
10	OX-14S	SPRING - LEVEING	11.7 LBS.
11	OMX-22	LEVEING ROD - REAR	67.0 LBS.
11a	CS114-5	BOLT - 1 1/4" X 4" LG. GR. 5	1.2 LBS.
	LN1	LOCK NUT - 1 1/4"	0.1 LBS.
12	OX-64	SET BAR - ANGLE, FRNT. GNG.	11.2 LBS.
13	ON-67	PIN - J	2.0 LBS
14	ON-68	BLOCK AXLE MNTG.	29.1 LBS.
15	ON-69	CAP - AXLE MTG.	9.0 LBS.
15a	CS78712-5	BOLT - 7/8" X 7 1/2" LG. GR. 5	1.5 LBS.
	LW78	LOCK WASHER - 7/8"	N/A
	N78	NUT - 7/8"	N/A
16	ON-70	GANG FRAME BOLT (LONG) 2 PER DISC	10.0 LBS.
17	ON-71	GANG FRAME BOLT (SHORT) 6 PER DISC	10.1 LBS.
18	OX-66	SET BAR - ANGLE, REAR GNG.	9.0 LBS.
19	OW-1-21	STRAP - GANG TO FRAME, TOP	13.0 LBS.
20	OW-1-22	STRAP - GANG TO FRAME BOTTOM	14.0 LBS.
20a	SN112	SLOTTED NUT - 1 1/2"	0.8 LBS.
21	OMX-58	ROD - DEPTH CONTROL	79.9 LBS.
21a	CS114-5	BOLT - 1 1/4" X 5" LG. GR.5	2.3 LBS.
	LW114	LOCK WASHER - 1 1/4"	N/A
	N114	NUT - 1 1/4"	N/A
22	OX-140	PIN - TRANSPORT	3.9 LBS.
	BLD-33	KLICK PIN	0.2 LBS.
23	ON-60	CRANK DEPTH CONTROL	5.0 LBS
	SN112	SLOTTED NUT - 1 1/2"	0.8 LBS

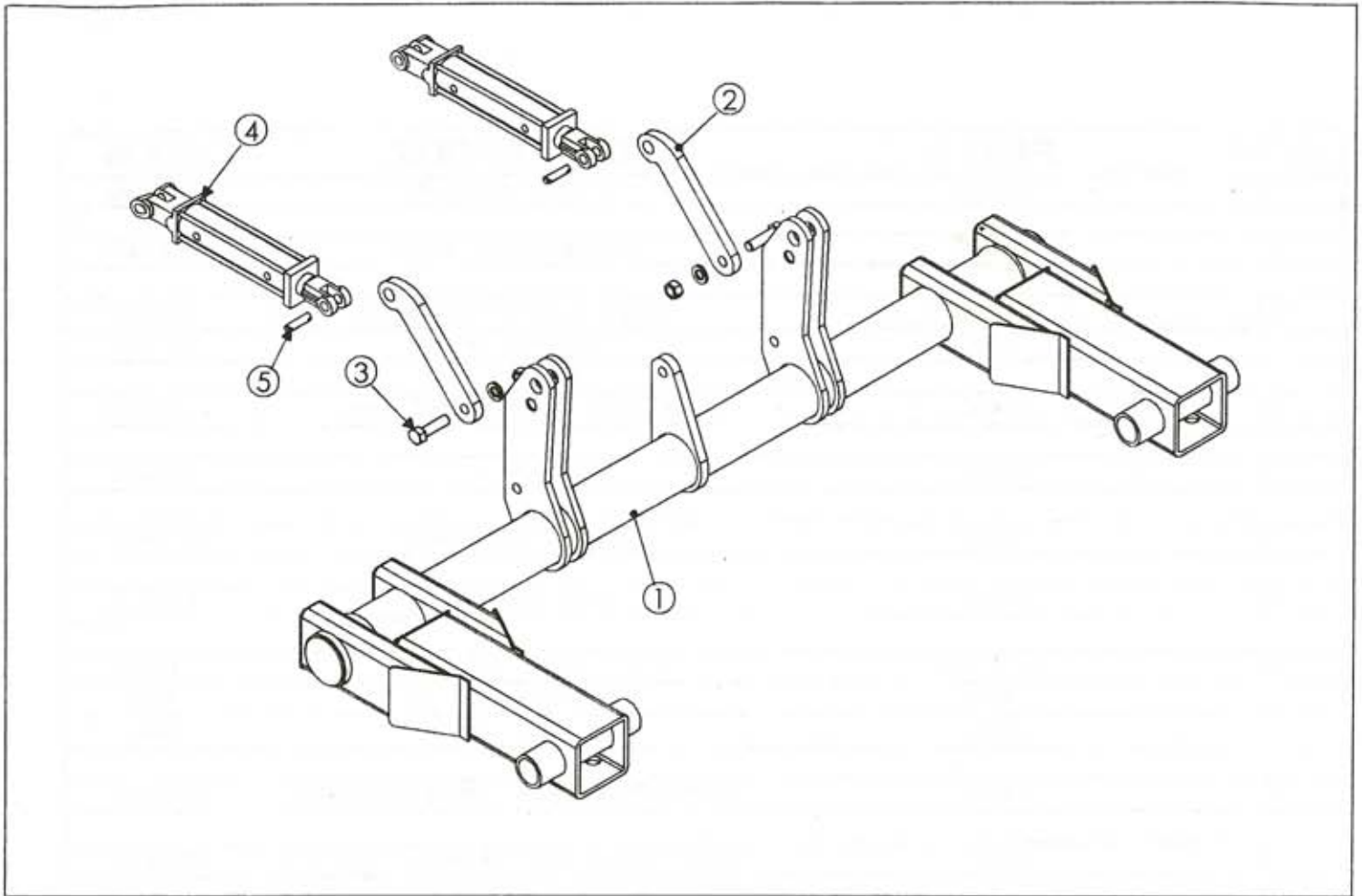

AXLE ASSEMBLY

REF#	PART #	DESCRIPTION	WT/LB.
1	OM-25	AXLE	459.0 LBS.
2	ON-56	AXLE SCISSOR	14.0 LBS.
3	CS1312-5	BOLT - 1" NC. X 3 1/2" LG. GR.5	1.1 LBS.
	LW1	LOCK WASHER - 1"	N/A
	N1	NUT - 1"	N/A
4	ON-53	HYD. CYLINDER 4" BORE X 16" STR.	57.0 LBS.
5	ON-55	PIN W RETAINER (HYD. CYL.)	0.9 LBS.

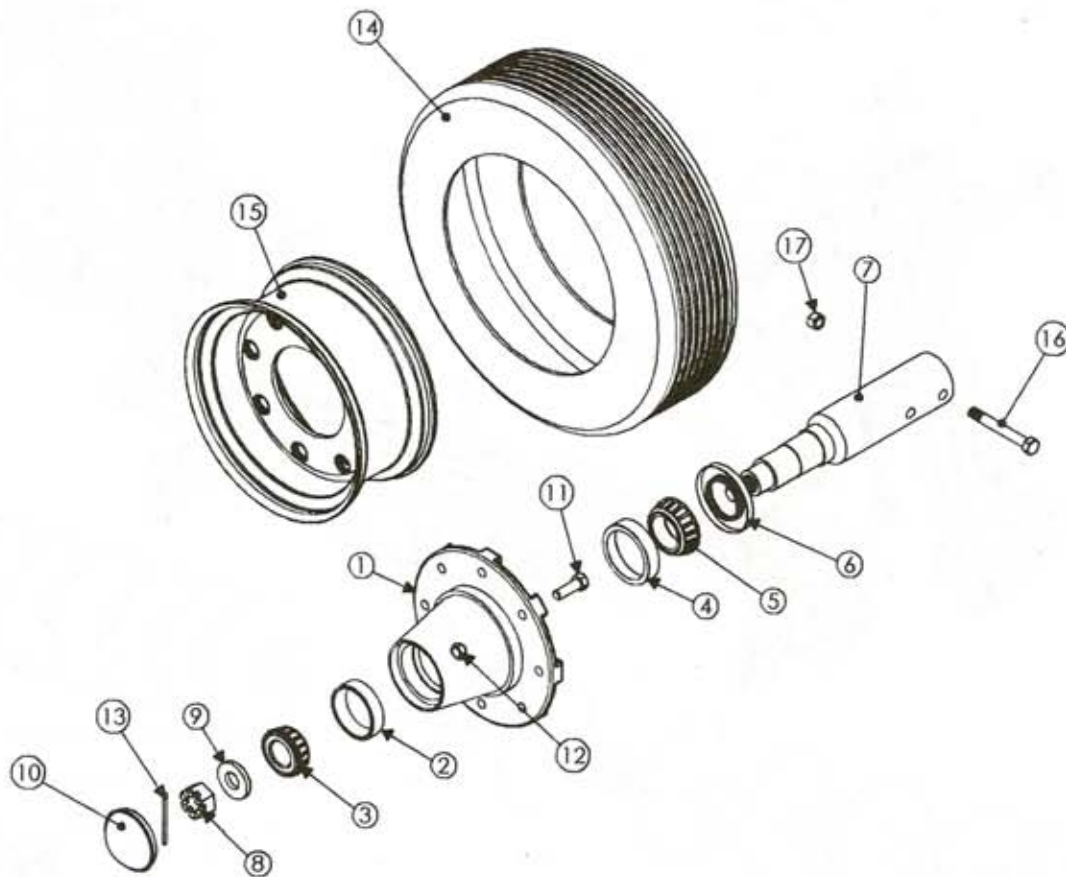

SPINDLE ASSEMBLY

1	RPO-163	HUB W/ CUPS	10.0 LBS.
2	RPO-147	BEARING CUP - OUTER	0.1 LBS.
3	RPO-148	BEARING CONE - OUTER	0.3 LBS.
4	RPO-145	BEARING CUP - INNER	0.2 LBS.
5	RPO-146	BEARING CONE - INNER	0.4 LBS.
6	RPO-144	OUTER SEAL	0.1 LBS.
7	FX-518	SLIP IN SPINDLE	9.0 LBS.
8	SN78F	SLOTTED NUT	0.1 LBS.
9	RPO-159	SPINDLE WASHER	0.01 LBS
10	RPO-151	DUST CAP	0.2 LBS.
11	RPO-168	LUG BOLT - (1/2" NG X 1" LG.)	0.1 LBS.
12	N916-F	NUT 9/16"	N/A
13	CP3162	COTTER PIN 3/16" X 2" LG.	N/A
14	FX-534	TIRE - 7.60-15, RIB 6 PLY.	24.0 LBS.
15	FX-533	WHEEL 15 X 6, 8 (1/2)	23.0 LBS.
16	CS12412-5	BOLT - 1/2" NC. X 4 1/2" GR.	N/A
17	LN-12	LOCK NUT - 1/2"	N/A

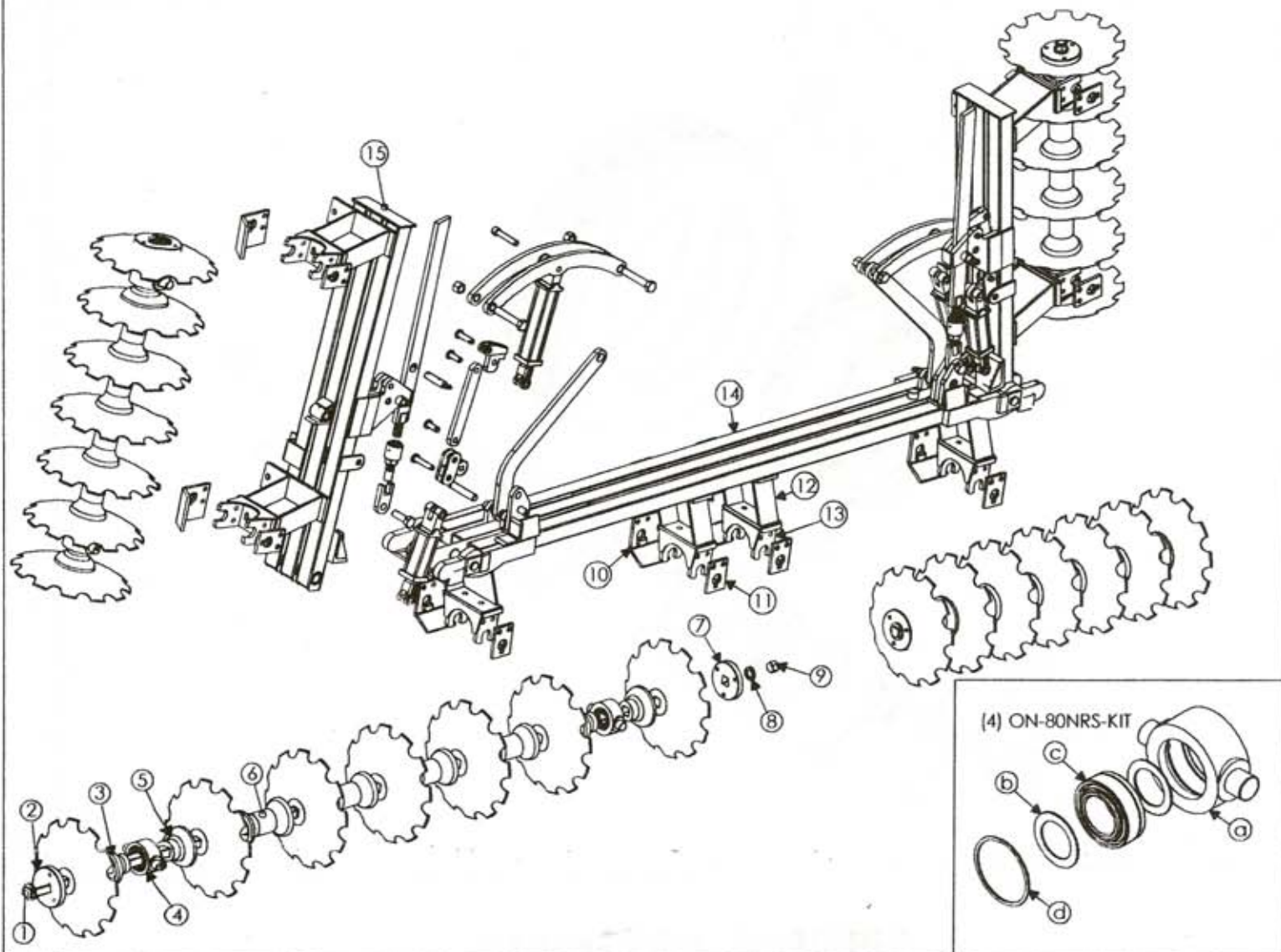

GANG ASSEMBLY

REF#	PART #	DESCRIPTION	WT/LB.
1	ON-105	GANG ROD - 1 1/2" SQ. 4 BLD. 9" SPC.	21.1 LBS.
	ON-106	GANG ROD - 1 1/2" SQ. 5 BLD. 9" SPC.	26.9 LBS.
	ON-107	GANG ROD - 1 1/2" SQ. 6 BLD. 9" SPC.	33.1 LBS.
	ON-108	GANG ROD - 1 1/2" SQ. 7 BLD. 9" SPC.	38.6 LBS.
	ON-109	GANG ROD - 1 1/2" SQ. 8 BLD. 9" SPC.	44.8 LBS.
	ON-110	GANG ROD - 1 1/2" SQ. 9 BLD. 9" SPC.	51.1 LBS.
	ON-111	GANG ROD - 1 1/2" SQ. 4 BLD. 10 1/2" SPC.	23.3 LBS.
	ON-112	GANG ROD - 1 1/2" SQ. 5 BLD. 10 1/2" SPC.	30.3 LBS.
	ON-113	GANG ROD - 1 1/2" SQ. 6 BLD. 10 1/2" SPC.	37.3 LBS.
	ON-114	GANG ROD - 1 1/2" SQ. 7 BLD. 10 1/2" SPC.	44.1 LBS.
	ON-115	GANG ROD - 1 1/2" SQ. 8 BLD. 10 1/2" SPC.	50.5 LBS.
	ON-116	GANG ROD - 1 1/2" SQ. 9 BLD. 10 1/2" SPC.	57.0 LBS.
	ON-118	GANG ROD - 1 1/2" SQ. 10 BLD. 10 1/2" SPC.	64.0 LBS.
ON-119	GANG ROD - 1 1/2" SQ. 11 BLD. 10 1/2" SPC.	71.0 LBS.	
2	JXE-19	EXT. WASHER - CCV, 1 1/2" SQ.	8.0 LBS.

REF#	PART #	DESCRIPTION	WT/LB.
15	MW1-04B-RF	WING - RIGHT HAND FRONT 4 BLD. 9" SPC.	N/A
	MW1-04B-LR	WING - LEFT HAND REAR 4 BLD. 9" SPC.	N/A
	MW1-02	WING - RIGHT HAND FRONT 5 BLD. 9" SPC.	N/A
	MW1-03	WING - LEFT HAND FRONT 5 BLD. 9" SPC.	N/A
	MW1-04	WING - RIGHT HAND REAR 5 BLD. 9" SPC.	N/A
	MW1-05	WING - LEFT HAND REAR 5 BLD. 9" SPC.	N/A
	MW1-06B-RF	WING - RIGHT HAND FRONT 6 BLD. 9" SPC.	N/A
	MW1-06B-LF	WING - LEFT HAND FRONT 6 BLD. 9" SPC.	N/A
	MW1-06B-RR	WING - RIGHT HAND REAR 6 BLD. 9" SPC.	N/A
	MW1-06B-LR	WING - LEFT HAND REAR 6 BLD. 9" SPC.	N/A
	MW1-07B-RF	WING - RIGHT HAND FRONT 7 BLD. 9" SPC.	N/A
	MW1-07B-LF	WING - LEFT HAND FRONT 7 BLD. 9" SPC.	N/A
	MW1-07B-RR	WING - RIGHT HAND REAR 7 BLD. 9" SPC.	N/A
	MW1-07B-LR	WING - LEFT HAND REAR 7 BLD. 9" SPC.	N/A
	MW1-08B-RF	WING - RIGHT HAND FRONT 8 BLD. 9" SPC.	N/A
	MW1-08B-LF	WING - LEFT HAND FRONT 8 BLD. 9" SPC.	N/A
	MW1-08B-RR	WING - RIGHT HAND REAR 8 BLD. 9" SPC.	N/A
	MW1-08B-LR	WING - LEFT HAND REAR 8 BLD. 9" SPC.	N/A
	MW1-09B-RF	WING - RIGHT HAND FRONT 9 BLD. 9" SPC.	N/A
	MW1-09B-LF	WING - LEFT HAND FRONT 9 BLD. 9" SPC.	N/A
	MW1-09B-RR	WING - RIGHT HAND REAR 9 BLD. 9" SPC.	N/A
	MW1-09B-LR	WING - LEFT HAND REAR 9 BLD. 9" SPC.	N/A
	OM2-01F	FRONT GANG - CENTER SECTION - 10 1/2" SPC.	1456.0 LBS.
	OM2-01R	REAR GANG - CENTER SECTION - 10 1/2" SPC.	1456.0 LBS.
	OM2-28	WING - RIGHT HAND FRONT, 4 BLD. 10 1/2" SPC.	N/A
	OM2-29	WING - LEFT HAND REAR, 4 BLD. 10 1/2" SPC.	N/A
	OM2-30	WING - RIGHT HAND FRONT, 5 BLD. 10 1/2" SPC.	926.0 LBS
	OM2-31	WING - LEFT HAND FRONT, 5 BLD. 10 1/2" SPC.	926.0 LBS.
	OM2-32	WING - RIGHT HAND REAR, 5 BLD. 10 1/2" SPC.	N/A
	OM2-33	WING - LEFT HAND REAR, 5 BLD. 10 1/2" SPC.	N/A
	OM2-34	WING - RIGHT HAND FRONT, 6 BLD. 10 1/2" SPC.	N/A
	OM2-35	WING - LEFT HAND FRONT, 6 BLD. 10 1/2" SPC.	N/A
	OM2-36	WING - RIGHT HAND REAR, 6 BLD. 10 1/2" SPC.	N/A
	OM2-37	WING - LEFT HAND REAR, 6 BLD. 10 1/2" SPC.	N/A
	OM2-38	WING - RIGHT HAND FRONT, 7 BLD. 10 1/2" SPC.	N/A
	OM2-39	WING - LEFT HAND FRONT, 7 BLD. 10 1/2" SPC.	N/A
	OM2-40	WING - RIGHT HAND REAR, 7 BLD. 10 1/2" SPC.	N/A
	OM2-41	WING - LEFT HAND REAR, 7 BLD. 10 1/2" SPC.	N/A
	OM2-42	WING - RIGHT HAND FRONT, 8 BLD. 10 1/2" SPC.	N/A
	OM2-43	WING - LEFT HAND FRONT, 8 BLD. 10 1/2" SPC.	N/A
	OM2-44	WING - RIGHT HAND REAR, 7 BLD. 10 1/2" SPC.	N/A
	OM2-45	WING - LEFT HAND REAR, 8 BLD. 10 1/2" SPC.	N/A

REF#	PART #	DESCRIPTION	WT/LB.
3	OF-84-SS	HALF SPOOL - CVX, 1 1/2" SQ. 9" SPC.	8.3 LBS.
	OF-84-S-F	HALF SPOOL - CVX, 1 1/2" SQ. 9" SPC. (STEEL FAB)	N/A
	OF-84L-SS	HALF SPOOL - CVX, 1 1/2" SQ. 10 1/2" SPC.	12.6 LBS.
	OF-84L-SS-F	HALF SPOOL - CVX, 1 1/2" SQ. 10 1/2" SPC. (STEEL FAB)	N/A
4	ON-80NRS-KIT	BEARING ASSY. - 1 1/2" SQ. NON-RELUBE SHIELDED	14.0 LBS.
a	ON-138	BRG. HSG. 1 1/2" SQ. (INCLUDES SHIELDS)	8.2 LBS.
b	ON-136	BRG. SHIELDS	0.5 LBS.
c	RPO-103I	BRG. GANG, 1 1/2" SQ. NR, IMPORT	3.2 LBS.
d	RPO-99	RETAINING RING	0.1 LBS.
5	OF-83-SS	HALF SPOOL - CCV, 1 1/2" SQ. 9" & 10 1/2" SPC.	N/A
	OF-83-SS-F	HALF SPOOL - CCV, 1 1/2" SQ. 9" & 10 1/2" SPC. (STEEL FAB)	N/A
6	OF-9	SPACER SPOOL 1 1/2" SQ., 9" SPC.	23.8 LBS.
	OF-9-F	SPACER SPOOL 1 1/2" SQ., 9" SPC. (STEEL FAB)	N/A
7	JXE-19	EXT. WASHER - CVX, 1 1/2" SQ.	8.0 LBS.
8	LW112	LOCK WASHER - 1 1/2"	0.2 LBS.
9	SN112	SLOTTED NUT - 1 1/2"	0.8 LBS.
10	ON-222F	BRG. CAP W/GUARD 1 1/2" SQ. (FRONT GANG)	7.6 LBS.
	ON-222R	BRG. CAP W/GUARD 1 1/2" SQ. (REAR GANG)	7.6 LBS.
	CS58134-5	BOLT - 5/8"NC. X 1 3/4" LG. GR. 5	0.3 LBS.
	LW58	LOCK WASHER - 5/8"	0.1 LBS.
	N58	NUT - 5/8"	
11	ON-223	BRG. STRAP CAP - 1 1/2" SQ. (SHORT)	2.1 LBS.
	CS58214	BOLT - 5/8" X 2 1/4" LG. GR. 5	0.5 LBS.
	LW58	LOCK WASHER - 5/8"	0.3 LBS.
	N58	NUT - 5/8"	0.1 LBS.
12	ON-225	BRACKET - BRG., FRONT	45.0 LBS.
	ON-226	BRACKET - BRG., REAR	45.0 LBS.
13	ON-224	BRG. HOLDER - ADJ. - 1 1/2" SQ.	10.1 LBS.
14	MW1-01F	FRONT GANG - CENTER SECTION 9" SPC.	1125.0 LBS.
	MW1-01R	REAR GANG - CENTER SECTION 9" SPC.	1125.0 LBS.

REF#	PART #	DESCRIPTION	WT/LB.
15	MW1-04B-RF	WING - RIGHT HAND FRONT 4 BLD. 9" SPC.	N/A
	MW1-04B-LR	WING - LEFT HAND REAR 4 BLD. 9" SPC.	N/A
	MW1-02	WING - RIGHT HAND FRONT 5 BLD. 9" SPC.	N/A
	MW1-03	WING - LEFT HAND FRONT 5 BLD. 9" SPC.	N/A
	MW1-04	WING - RIGHT HAND REAR 5 BLD. 9" SPC.	N/A
	MW1-05	WING - LEFT HAND REAR 5 BLD. 9" SPC.	N/A
	MW1-06B-RF	WING - RIGHT HAND FRONT 6 BLD. 9" SPC.	N/A
	MW1-06B-LF	WING - LEFT HAND FRONT 6 BLD. 9" SPC.	N/A
	MW1-06B-RR	WING - RIGHT HAND REAR 6 BLD. 9" SPC.	N/A
	MW1-06B-LR	WING - LEFT HAND REAR 6 BLD. 9" SPC.	N/A
	MW1-07B-RF	WING - RIGHT HAND FRONT 7 BLD. 9" SPC.	N/A
	MW1-07B-LF	WING - LEFT HAND FRONT 7 BLD. 9" SPC.	N/A
	MW1-07B-RR	WING - RIGHT HAND REAR 7 BLD. 9" SPC.	N/A
	MW1-07B-LR	WING - LEFT HAND REAR 7 BLD. 9" SPC.	N/A
	MW1-08B-RF	WING - RIGHT HAND FRONT 8 BLD. 9" SPC.	N/A
	MW1-08B-LF	WING - LEFT HAND FRONT 8 BLD. 9" SPC.	N/A
	MW1-08B-RR	WING - RIGHT HAND REAR 8 BLD. 9" SPC.	N/A
	MW1-08B-LR	WING - LEFT HAND REAR 8 BLD. 9" SPC.	N/A
	MW1-09B-RF	WING - RIGHT HAND FRONT 9 BLD. 9" SPC.	N/A
	MW1-09B-LF	WING - LEFT HAND FRONT 9 BLD. 9" SPC.	N/A
	MW1-09B-RR	WING - RIGHT HAND REAR 9 BLD. 9" SPC.	N/A
	MW1-09B-LR	WING - LEFT HAND REAR 9 BLD. 9" SPC.	N/A
	OM2-01F	FRONT GANG - CENTER SECTION - 10 1/2" SPC.	1456.0 LBS.
	OM2-01R	REAR GANG - CENTER SECTION - 10 1/2" SPC.	1456.0 LBS.
	OM2-28	WING - RIGHT HAND FRONT, 4 BLD. 10 1/2" SPC.	N/A
	OM2-29	WING - LEFT HAND REAR, 4 BLD. 10 1/2" SPC.	N/A
	OM2-30	WING - RIGHT HAND FRONT, 5 BLD. 10 1/2" SPC.	926.0 LBS
	OM2-31	WING - LEFT HAND FRONT, 5 BLD. 10 1/2" SPC.	926.0 LBS.
	OM2-32	WING - RIGHT HAND REAR, 5 BLD. 10 1/2" SPC.	N/A
	OM2-33	WING - LEFT HAND REAR, 5 BLD. 10 1/2" SPC.	N/A
	OM2-34	WING - RIGHT HAND FRONT, 6 BLD. 10 1/2" SPC.	N/A
	OM2-35	WING - LEFT HAND FRONT, 6 BLD. 10 1/2" SPC.	N/A
	OM2-36	WING - RIGHT HAND REAR, 6 BLD. 10 1/2" SPC.	N/A
	OM2-37	WING - LEFT HAND REAR, 6 BLD. 10 1/2" SPC.	N/A
	OM2-38	WING - RIGHT HAND FRONT, 7 BLD. 10 1/2" SPC.	N/A
	OM2-39	WING - LEFT HAND FRONT, 7 BLD. 10 1/2" SPC.	N/A
	OM2-40	WING - RIGHT HAND REAR, 7 BLD. 10 1/2" SPC.	N/A
	OM2-41	WING - LEFT HAND REAR, 7 BLD. 10 1/2" SPC.	N/A
	OM2-42	WING - RIGHT HAND FRONT, 8 BLD. 10 1/2" SPC.	N/A
	OM2-43	WING - LEFT HAND FRONT, 8 BLD. 10 1/2" SPC.	N/A
	OM2-44	WING - RIGHT HAND REAR, 7 BLD. 10 1/2" SPC.	N/A
	OM2-45	WING - LEFT HAND REAR, 8 BLD. 10 1/2" SPC.	N/A

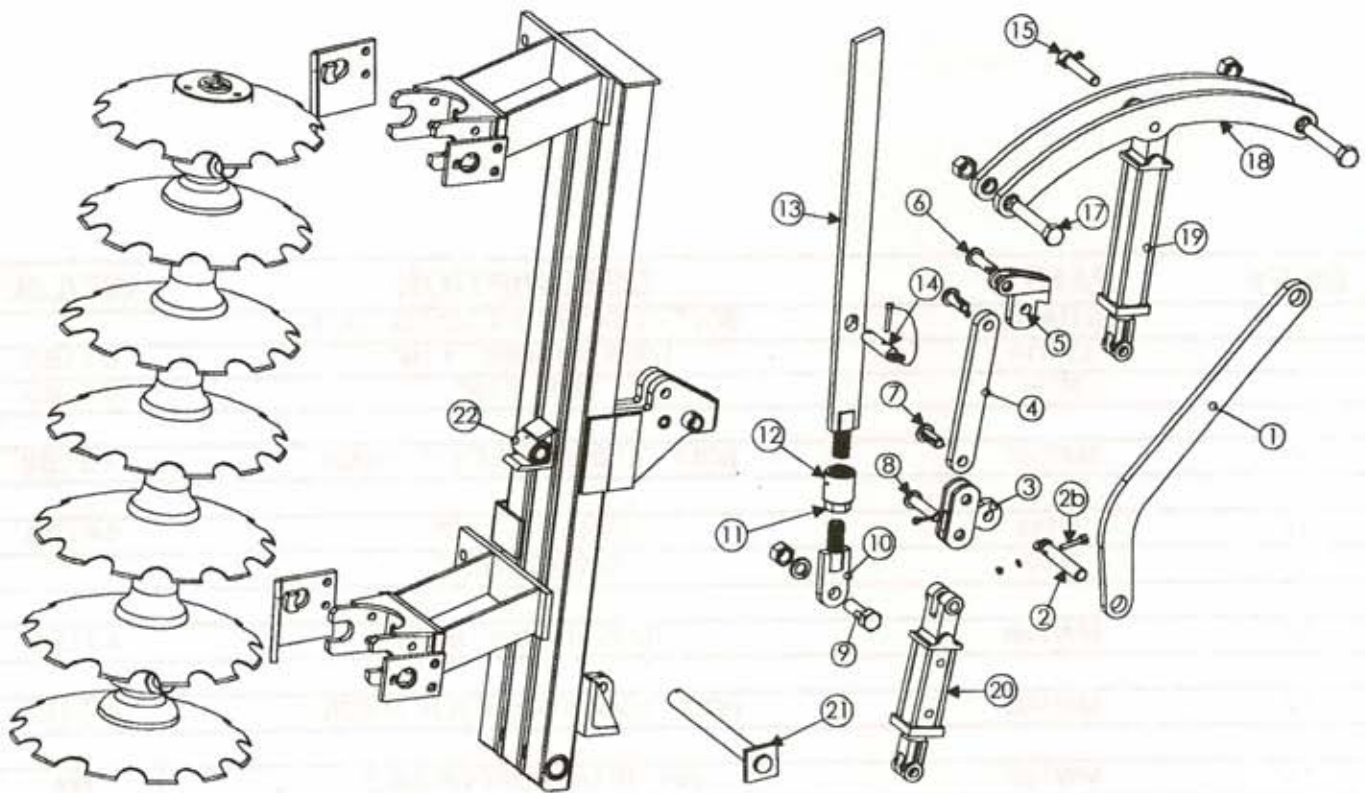

GANG WING ASSEMBLY

REF#	PART #	DESCRIPTION	WT/LB.
1	MW1-24	CONTROL ARM	36.5 LBS.
2	MW1-28	PIN LOCK DOWN	2.5 LBS.
2b	CS38212-5	BOLT - 3/8" NC. X 2 1/2" LG. GR. 5	N/A
	LW38	LOCK WASHER - 3/8"	N/A
	N38	NUT - 3/8"	N/A
3	MW1-33	PIVOT - BRACKET - LOCK DOWN	9.0 LBS.
4	MW1-32	LINK - LOCK DOWN	10.5 LBS.
5	MW1-29	LOCK DOWN TOGGLE	7.5 LBS.
6	MW1-35	PIN - LOCK DOWN	1.0 LBS.
	CP5163	COTTER PIN - 5/16" X 3" LG.	
7	MW1-34	PIN - LOCK DOWN	1.0 LBS.
	CP5163	COTTER PIN - 5/16" X 3" LG.	
8	MW1-36	PIN-LOCK DOWN	1.0 LBS.
	CP5163	COTTER PIN - 5/16" X 3" LG.	N/A

REF#	PART #	DESCRIPTION	WT/LB.
9	CS114412-5	BOLT - 1 1/4" NC. X 4 1/2" LG. GR. 5	
	LW114	LOCK WASHER - 1 1/4"	0.1 LBS.
	N114	NUT - 1 1/4"	0.6 LBS.
10	MW1-07	BOLT - TURN BUCKLE L.H. THRDS.	4.5 LBS
11	JN112	JAM NUT - 1 1/2"	0.6 LBS.
	7000	GREASE ZERK	
12	MW1-08	TURN BUCKLE - BODY	4.2 LBS.
13	MW1-06	BOLT - TURN BUCKLE R.H. THRDS.	26.5 LBS.
14	MW1-25	PIN - TRANSPORT W/CABLE	N/A
15	MW1-09	PIN - HYD. CYL. TO PIVOT ARMS	1.9 LBS.
	CP5163	COTTER PIN - 5/16" X 3" LG.	N/A
16	MW1-11	PIVOT - ARM LEFT HAND	33.3 LBS.
17	CS114712-5	BOLT - 1 1/4" NC. X 7 1/2" LG. GR. 5	3.2 LBS.
18	MW1-12	PIVOT - ARM RIGHT HAND	33.3 LBS.
19	JJ-90	HYD. CYLINDER - 3" DIA. X 12" STRK. (W/PINS)	30.0 LBS.
20	MW1-37	HYD. CYLINDER - 2 1/4" DIA. X 4" STRK. (LOCK CYL.)	N/A
21	MW1-10	PIN -WING PIVOT	12.1 LBS
22	1641	GREASE ZERK -1/4-28	N/A

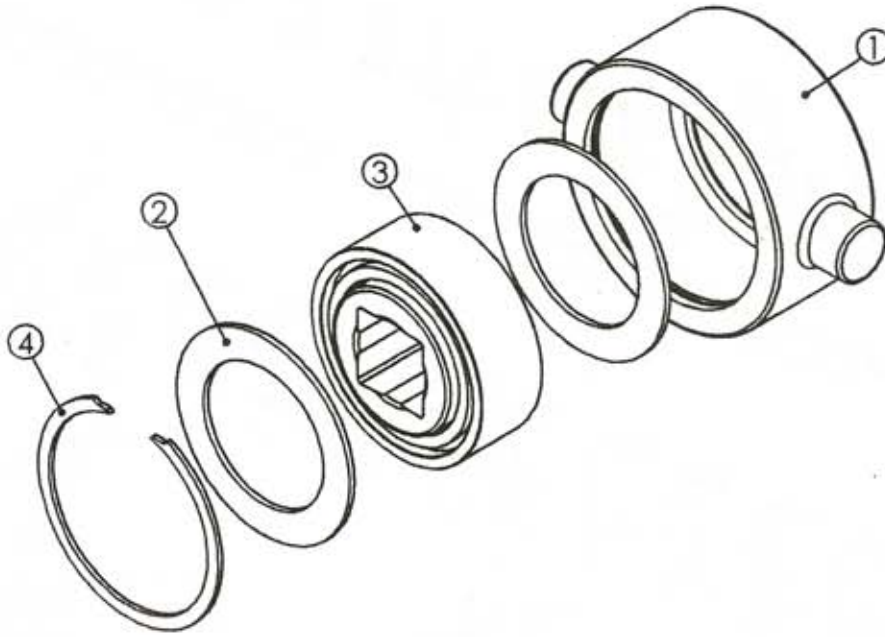

ON-80NRS-KIT

REF#	PART #	DESCRIPTION	WT/LB.
1	ON-138	BRG. - HOUSING	
2	ON-136	BRG. - SHIELDS	
3	RPO-103I	BRG. 1 1/2" SQ. RELUBE (W211PP5)	
4	RP0-99	SNAP RING	

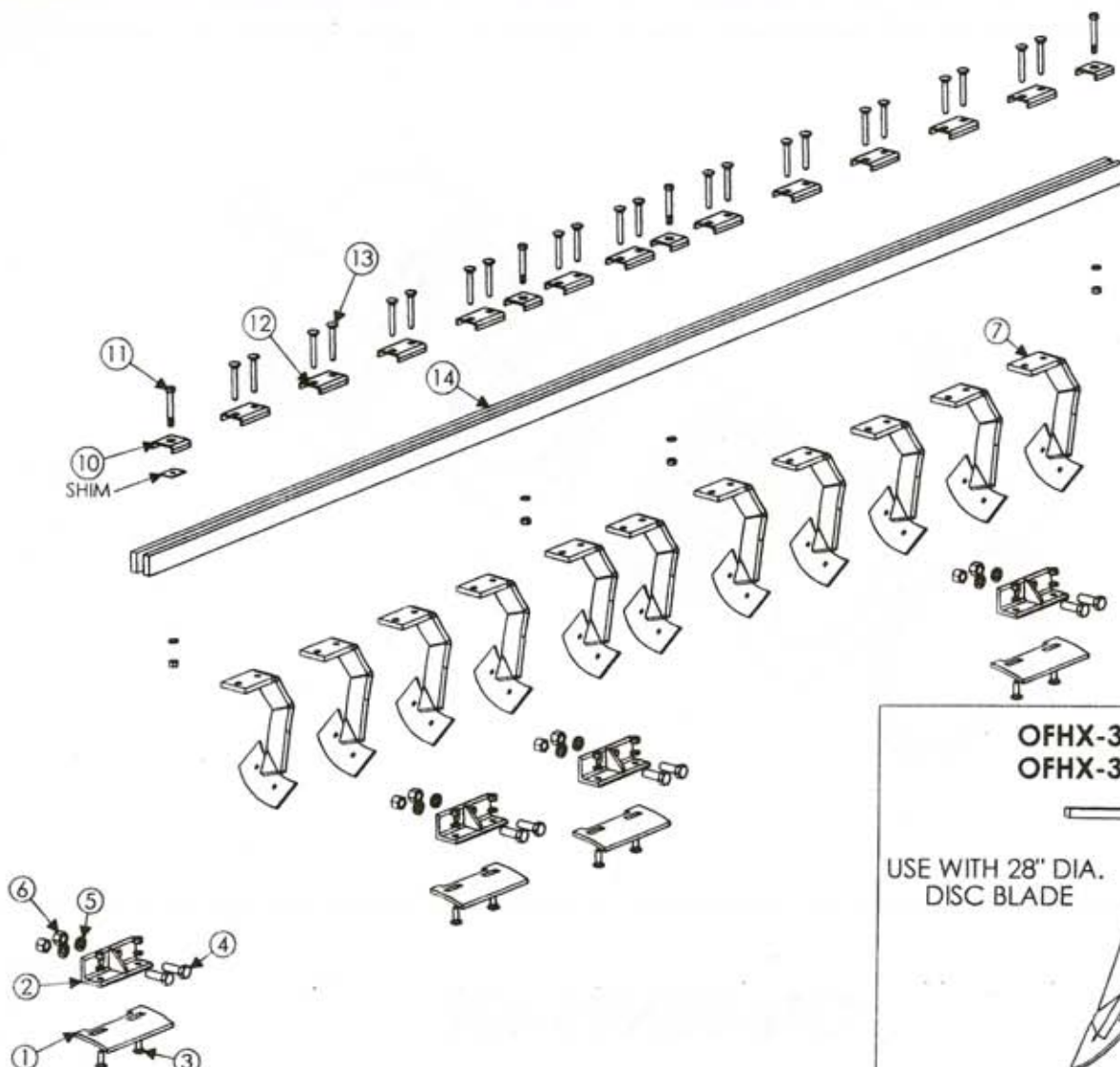

CLEANER ASSEMBLY

REF#	PART #	DESCRIPTION	WT/LB.
1	ON-157	THRASH PLATE - 9" SPACING	5.0 LBS.
	FXSL-230	THRASH PLATE - 10 1/2" SPACING	5.8 LBS.
2	ON-158	HOLDER - TRASH PLATE (ON-157)	4.2 LBS.
	FXSL-229	HOLDER - TRASH PLATE (FXSL-230)	4.0 LBS.
3	CB12112-5	CARRIAGE BOLT - 1/2" NC. X 1 1/2" LG. GR. 5	0.2 LBS.
	LW12	LOCK WASHER - 1/2"	0.1 LBS.
	N12	NUT - 1/2"	0.1 LBS.
4	CS58214-5	BOLT - 5/8" NC. X 2 1/4" LG. GR. 5	0.3 LBS.
5	LW58	LOCK WASHER - 5/8"	0.1 LBS.
6	N58	NUT - 5/8"	0.1 LBS.
7	OFH-300-F	CLEANER ARM - FRONT HVY. DTY.	N/A
	OFHX-300-F	CLEANER ARM - FRONT (WHEN USING 28" DISC BLADES ONLY)	N/A
	OFH-300-R	CLEANER ARM - REAR HVY. DTY.	N/A
	OFHX-300-R	CLEANER ARM - REAR (WHEN USING 28" DISC BLADES ONLY)	N/A
8	OF-309	BLADE CLEANER	2.0 LBS.

REF#	PART #	DESCRIPTION	WT/LB.
9	CB381-5	CARRICGE BOLT - 3/8" NC. X 1" LG. GR. 5	N/A
	LW38	LOCK WASHER - 3/8"	N/A
	N38	NUT - 3/8"	N/A
10	OF-307-W	CAP - CLEANER BAR W/SHIM (ON CENTER GANGS ONLY)	N/A
	OF-307	CAP - CLEANER BAR - STANDARD	N/A
11	CS34412-5	BOLT - 3/4" NC. X 4 1/2" LG. GR. 5	N/A
	LW34	LOCK WASHER - 3/4"	N/A
	N34	NUT - 3/4"	N/A
12	OF-305	CAP CLEANER ARM	0.5 LBS.
13	CB12312-5	CARRIGE BOLT - 1/2" NC. X 3 1/2" LG. GR. 5	N/A
	LW12	LOCK WASHER - 1/2"	N/A
	N12	NUT - 1/2"	N/A
14	MWC-1	CLEANER BAR - CENTER GANG (WING DISC) 133" LG.	N/A
	MWC-4	CLEANER BAR - 4 BLADE , 9" SPC. 39" LG.	N/A
	MWC-5	CLEANER BAR - 5 BLADE , 9" SPC.48" LG.	N/A
	MWC-6	CLEANER BAR - 6 BLADE , 9" SPC. 57" LG.	N/A
	MWC-7	CLEANER BAR -7 BLADE , 9" SPC. 66" LG.	N/A
	MWC-8	CLEANER BAR - 8 BLADE , 9" SPC. 76" LG.	N/A
	MWC-9	CLEANER BAR - 9 BLADE , 9" SPC. 85" LG.	N/A
	OMC-4	CLEANER BAR - 4 BLADE , 10 1/2" SPC. 44" LG.	N/A
	ONC-5	CLEANER BAR - 5 BLADE , 10 1/2" SPC. 55" LG.	N/A
	OMC-6	CLEANER BAR -6 BLADE , 10 1/2" SPC. 66" LG.	N/A
	OMC-7	CLEANER BAR -7 BLADE , 10 1/2" SPC. 77" LG.	N/A
	OMC-8	CLEANER BAR -8 BLADE , 10 1/2" SPC. 88" LG.	N/A
OPTIONAL CLEANER ASSY.			
	OFH-300A-F	CLEANER ASSY. - HVY. DTY.	N/A
	OFH-300A-R	CLEANER ASSY. - HVY. DTY.	N/A
	OFHX-300A-F	CLEANER ASSY. - HVY. DTY. (USE W/28" D BLD.)	N/A
	OFHX-300A-R	CLEANER ASSY. - HVY. DTY. (USE W/28" D BLD.)	N/A

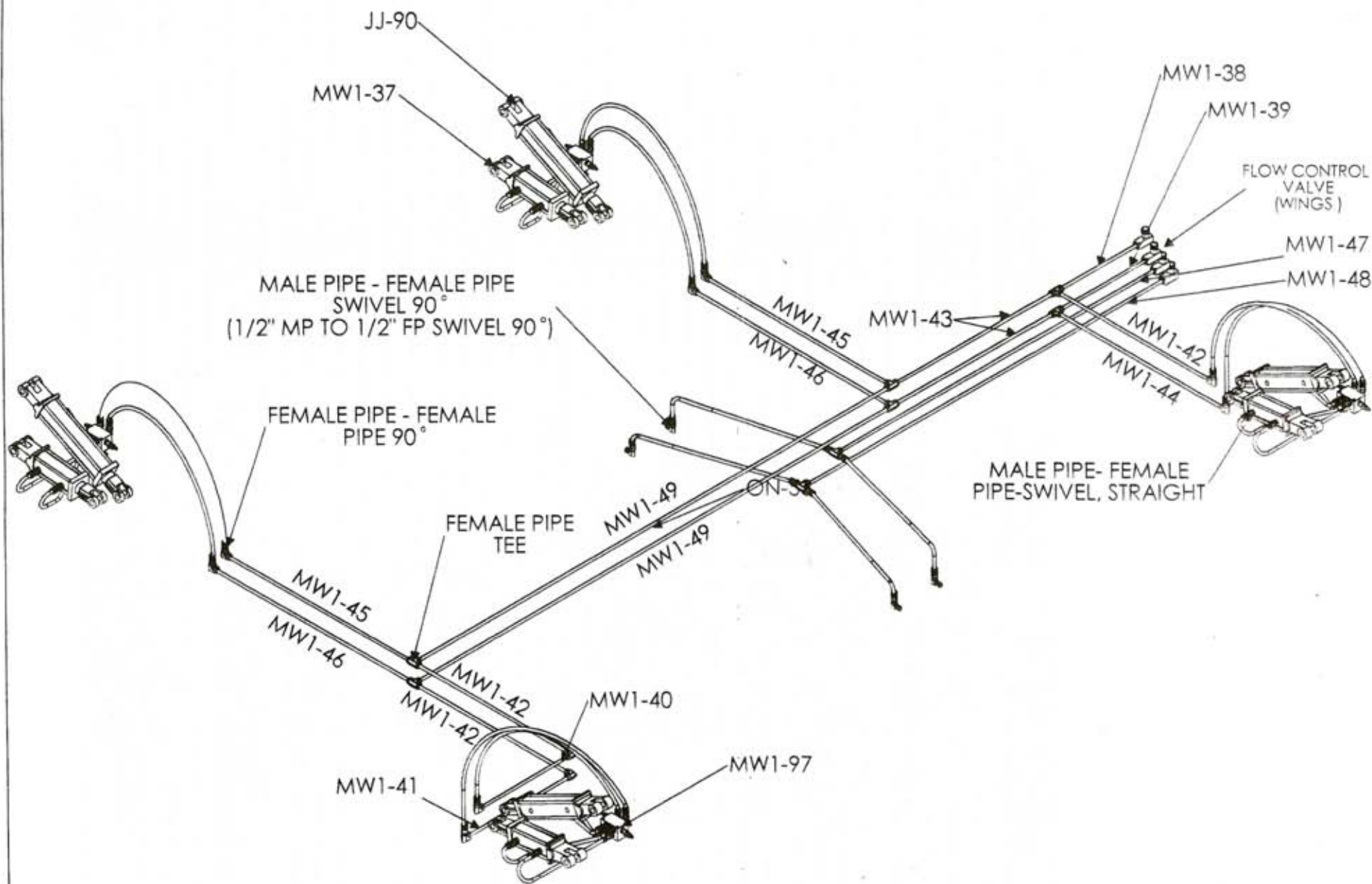

OFMX-W HYDRAULIC SYSTEM

1.

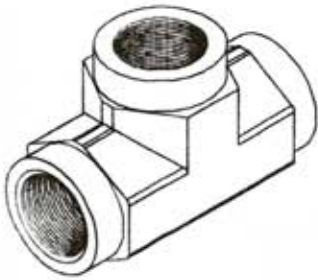
**FPT-8**

2.

**FP-FP90-8-8**

3.

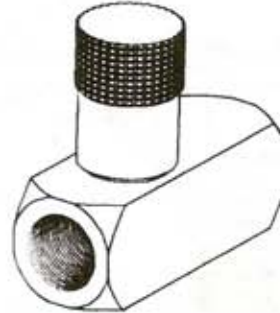
**PF800-S**

4.

**FP-FPX-8-8**

5.

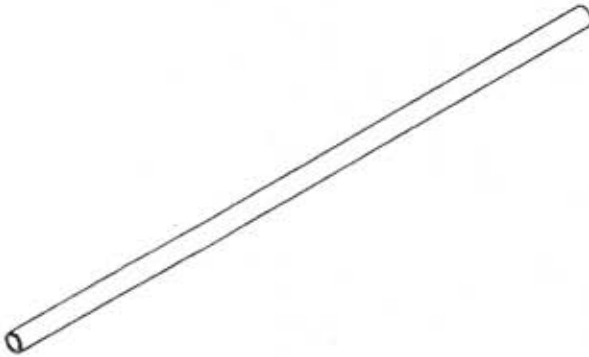
**MW1-38 THROUGH MW1-49**

6.

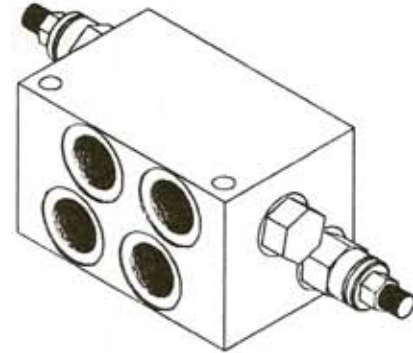
**MW1-97**

HYDRAULIC ATTACHMENTS

REF#	PART #	DESCRIPTION	WT/LB.
1	FPT-8	FEMALE PIPE TEE - 1/2" FP - 1/2" FP - 1/2" FP	0.5 LBS
2	FP-FP90-8-8	FEMALE PIPE - FEMALE PIPE 90	0.5 LBS.
3	PF800-S	FLOW VALVE CONTROL	1.5 LBS.
4	FP-FPX-8-8	FEMALE PIPE - FEMALE PIPE SWIVEL - STRAIGHT	0.5 LBS.
5	MW1-38	HYDRAULIC PIPE - WING FOLD 17 1/2" LG.	
	MW1-39	HYDRAULIC PIPE - WING FOLD 19 1/2" LG.	
	MW1-40	HYDRAULIC PIPE - WING FOLD 20" LG.	
	MW1-41	HYDRAULIC PIPE - WING FOLD 23" LG.	
	MW1-42	HYDRAULIC PIPE - WING FOLD 34 1/2" LG.	
	MW1-43	HYDRAULIC PIPE - WING FOLD 36 1/2" LG.	
	MW1-44	HYDRAULIC PIPE - WING FOLD 37 1/2" LG.	
	MW1-45	HYDRAULIC PIPE - WING FOLD 42" LG.	
	MW1-46	HYDRAULIC PIPE - WING FOLD 45" LG.	
	MW1-47	HYDRAULIC PIPE - WING FOLD 74" LG.	
	MW1-48	HYDRAULIC PIPE - WING FOLD 84" LG.	
	MW1-49	HYDRAULIC PIPE - WING FOLD 111" LG.	
6	MW1-97	SEQUENCING VALVE	

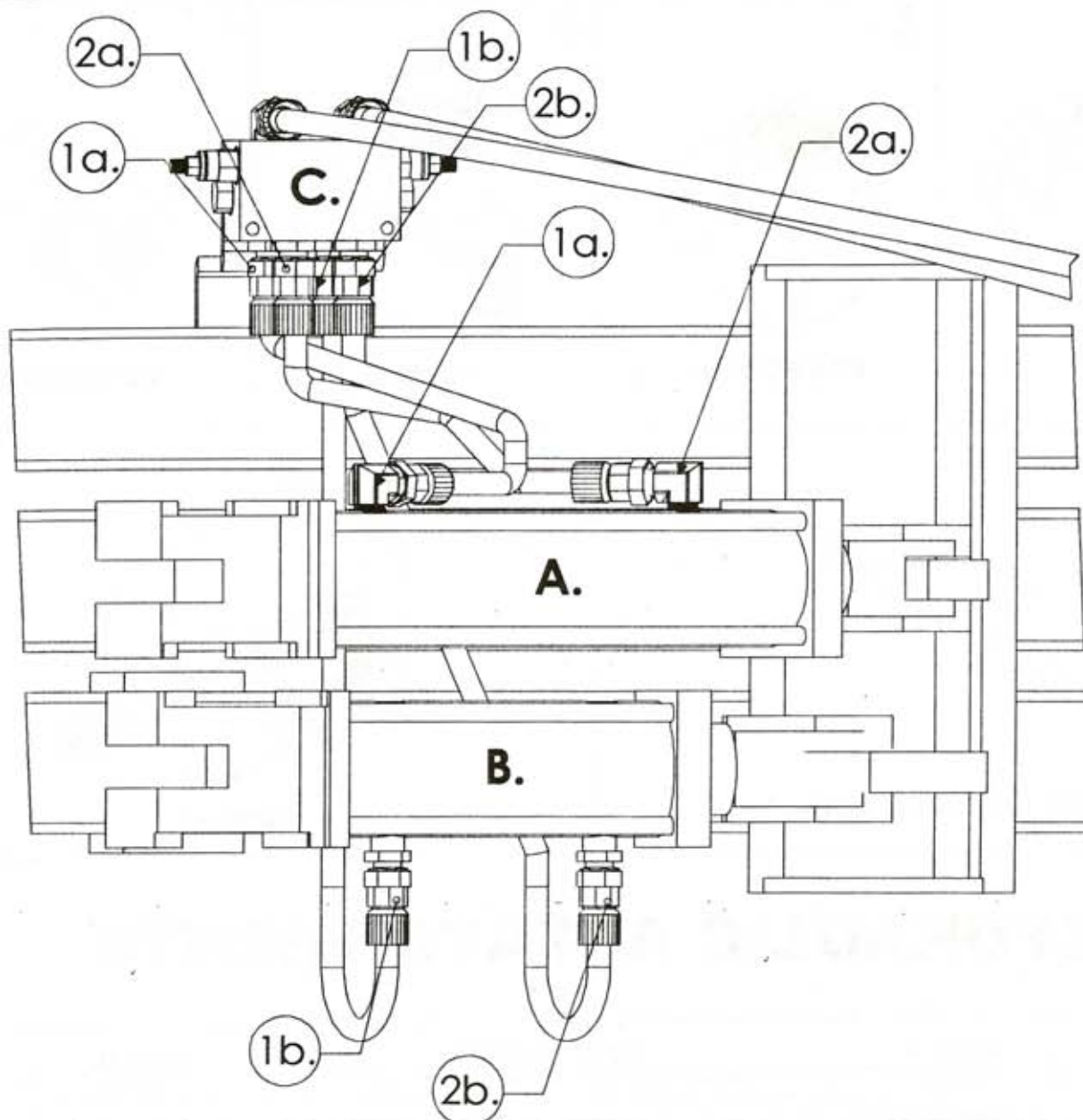

REF#	PART #	DESCRIPTION	WT/LB.
A.	JJ-90	HYD. CYLINDER 3" DIA. X 12" STRK. (W/PINS)	
1a.	HYDRAULIC HOSE	CONNECT BOTTOM LEFT OF SEQUENCING VALVE C. TO LEFT SIDE OF HYRAULIC A.	
2a.	HYDRAULIC HOSE	CONNECT TOP LEFT OF SEQUENCING VALVE C. TO RIGHT SIDE OF HYRAULIC A	
B.	MW-1-37	HYD. CYLINDER 2 1/4" DIA. X 4" STRK. (LOCK CYL.)	
1b.	HYDRAULIC HOSE	CONNECT BOTTOM RIGHT OF SEQUENCING VALVE C. TO LEFT SIDE OF HYRAULIC B.	
2b.	HYDRAULIC HOSE	CONNECT TOP RIGHT OF SEQUENCING VALVE C. TO RIGHT OF HYRAULIC B.	
C.	MW1-97	SEQUENCING VALVE	