

H.W.O. SERIES

**PARTS
AND
OPERATER
MANUAL**

**HEAVY
DUTY
LOW
PROFILE
FOR
ORCHARD
AND
OPEN
FEILD**

Domries Enterprises, Inc

12281 Rd 29

Madera, California 93638

Phone (559) 673-9143

Fax (559) 673-4110

Visit our Web-Site at

www.domriesentinc.com

IMPORTANT! PLEASE READ!

TO OUR CUSTOMER – USER’S RESPONSIBILITY – WARRANTY

TO OUR CUSTOMER

The following pages and illustrations are printed to help supply you with the knowledge to better operate and service your new **DOMRIES** equipment.

We are proud to have you as a customer and feel you will be proud to be a **DOMRIES** owner.

Any piece of equipment needs, and must have a certain amount of service and maintenance to keep it in top running condition. We have attempted to cover all the adjustments required to fit most conditions; however, there may be times special care must be taken to fit a condition.

Study this operator’s manual carefully and become acquainted with all the adjustments and operating procedures before attempting to operate your new equipment. Remember, it is a machine and has been designed and tested to do an efficient job in most operating conditions and will perform in relation to the service it receives.

If special attention is required for some conditions, ask your **DOMRIES** dealer; his Parts and Service Organization will be glad to help and answer any question on operation and service of your new machine.

ATTENTION! BECOME ALERT!

YOUR SAFETY IS INVOLVED

This symbol is used to call your attention to safety precautions that should be followed by the operator to avoid accidents. When you see this symbol – Heed Its Warning.

USER’S RESPONSIBILITY

It is the responsibility of the user to read the Operator’s Manual and understand the safe and correct operating procedures as pertains to the operation of the product, and to lubricate and maintain the product according to the maintenance schedule in the Operator’s Manual.

The user is responsible for inspecting his machine and for having parts repaired or replaced when continued use of the product would cause damage or excessive wear to other parts. It is the user’s responsibility to deliver his machine to a **DOMRIES** dealer, for service or replacement of defective parts which are covered by the standard warranty. When requesting warranty service, you present your copy of delivery record.

MODEL# _____

SERIAL# _____



Safety Precautions

**ATTENTION! BECOME ALBERT!
YOUR SAFETY IS INVOLVED!**

This symbol is used to call your attention to safety precautions. That should be followed by the operator to avoid accidents. When you see this – Heed Its Warning.

Many hours of lost time and much suffering is caused by the failure to practice simple safety rules.

1. **READ** this manual carefully to acquaint your - self with the Disk Harrow. Opening unfamiliar equipment can cause accidents.
2. **LOWER IMPLEMENT** if possible, when adjusting maintenance work; otherwise **BLOCKS IT SECURELY** at a workable height.
3. When Implement and tractor are parked always lower disk to the ground and place a **FLAG OR OTHER WAARMING DEVICE** on each corner as someone could run or bump into the implement.
4. Implement should be **DETACHED ONLY** in an area where Children **DO NOT PLAY**.
5. **DO NOT** wear loose fitting clothing that could catch on various parts.
6. Machinery should be **OPERATED ONLY** by those who are **RESPONSIBLE AND DEEGATED** to do so.
7. **ONLY ONE PERSON** – the operator – should be permitted on the tractor when implement is in operation, he should be thoroughly familiar with tractor and implement.
8. **MAKE CERTAIN** that everyone is in clear before starting tractor and implement combination.
9. **BEFORE WORKING** under the any hydraulically controlled unit IS SURE it is **SECURELY BLOCKED**.
10. The **RATE OF SPEED** on hillsides or curves should be regulated so there is no danger of tipping.
11. **DO Not** drive too close to the edge of a ditch or creek.
12. **REDUCE SPEED** when transporting unit to avoid bouncing and momentary loss of steer ability.
13. **MAKE CERTAIN** tractor is equipped with sufficient front end weight to counter-balance the plow weight and maintain stability of front of tractor.
14. **DO NOT** attempt to operate tractor and implement unless you are in the diver seat.
15. **ALWAYS** place transmission in **PARK or NEUTRAL, LOCK BRAKES,STOP ENGINE AND REMOVE START KEY** before dismounting from the tractor.
16. **NEVER** stand between tractor and disc when hitching.
17. **PROVIDE** a first aid kit. Treat all scratches, cuts, etc. with proper antiseptic immediately.
18. If **DECALS** become damaged or come off, they should be replaced immediately.
19. **REMEMBER** that safe operation is no accident.

ON HIGHWAY OPERATION

1. Use the **SLOW MOVING** vehicle emblem in daytime and approved warning lights at night, or during other periods of poor visibility, to prevent highway accidents.
2. **COMPLY** with Local highway regulation concerning moving machinery on highways.
3. **MAINTAIN** complete Control of machines at all times when traveling on the highway.
4. Due to the width of the implement, **US EXTRA CAUTION** on highways, far lanes and when approaching gates.

Domries Enterprises, Inc.

12281 Road 29
Madera, CA 93637



Phone (559) 673-9143

Fax (559) 673-4110

www.domreisentinc.com

WARRANTY

Domries warrant's all products of it's manufacture to be free of defects in material and workmanship under normal usage and maintenance for the period of one year from the date of delivery to the original purchaser.

RETURN GOODS

Domries shall have the option of requiring the prepaid return of any parts claimed defective, however, No parts shall be returned without Domries warranty form with good authorized number. Goods shall be returned to such location as shall be designed by Domries.

Domries will at it's option, either repair or replace, F.O.B. Domries factory. Such parts as appear to to Domries upon inspection, to have been defective in materials and/or workmanship. Wearing parts that are determined to be defective are subject to an adjustment based upon useful life.

REPAIRS

Any field or repairs must have the authorized repair number from Domries before any work is done. Claim for warranty must be made with a Domries warranty form and repair number.

Domries will not accept any charged other than its direct Dealer shop labor costs and part required to remedy such parts and/or workmanship at its Dealer place of business. The WARRANTY specifically excludes any charges for delivery, transportation, and/or shipping cost.

If the dealer is requested by the customer to travel or haul the machine to his shop or repair shop for the purpose of performing a warranty obligation or free inspection, it would be for the customers convenience, and the cost of such a trip is to be paid by the customer. Any arrangement whereby the Dealer agrees to absorb all or a part of the cost is to be made between the Dealer and the Customer. To be considered a courtesy to the Customer by their Dealer.

LIMITED WARRANTY

Outside purchase equipment and accessories (not of Domries manufacture) are warranted only to the extent of the original manufacture's warranty to Domries.

Item limited - Hydraulic cylinders and hose - Bearings - Disc Blades - Wheels - Tires - Tubes - Seals.

No Warranty shall be paid by Domries before the part or parts and labor have been paid to Domries by the manufacturer. Domries shall then compensate the dealer or customer.

NO WARRANTY

(1) New product that has been subjected to operation in excess in recommended capacities, misused, negligence, lack of maintenance or accident or have been altered or repaired in any manner not authorized by Domries.

(2) Sharp turns while machine is ground void warranty, with the exception of a drag disc.

Domries shall in no event be responsible for any delay or any other consequential or indirect damage in connection with fulfilling any obligation under this WARRANTY.

Domries reserves the right to make change at any time in designs, materials and/or specifications of it's product without becoming liable or obligated in any way to make similar changes in previously manufactured products.

This WARRANTY IS IN LIEU OF ALL OTHER WARRANTIES COVERING DOMRIES PRODUCTS and no other Warranties expressed or implied are made or authorized by Domries Enterprises, Inc.

This WARRANTY BECAME EFFECTIVE with shipments made on or after August 1st 1998

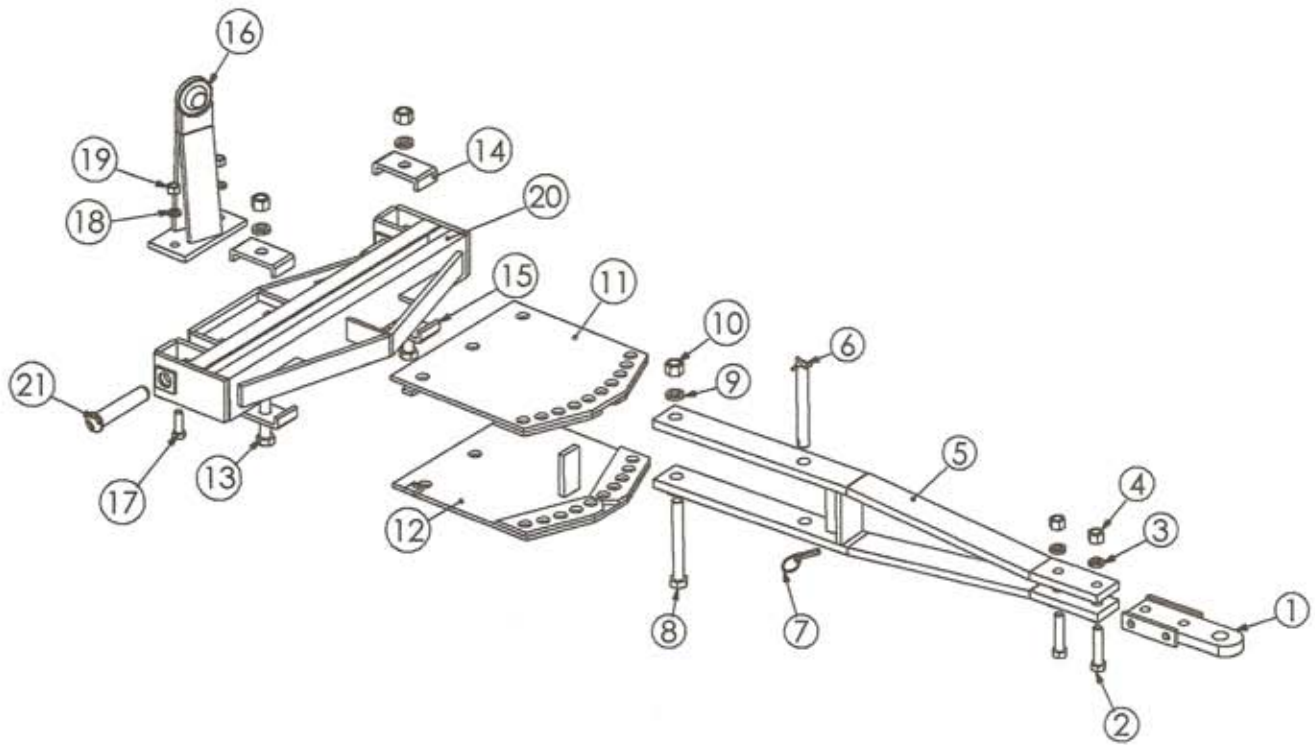

DRAW BAR, HITCH

REF. #	PART #	DESCRIPTION	APPROX. WT.
1	W1072	TONGUE	10.0 LBS.
2	CS34312-5	BOLT - 3/4" NC. X 3 1/2" LG. GR. 5	N/A
3	LW34	LOCK WASHER - 3/4"	N/A
4	N34	NUT - 3/4"	N/A
5	W1070	DRAW BAR - 5'3" TO 9' 9"	61.0 LBS.
6	W1064	PIN - HITCH ANGLE SET	N/A
7	BLD-33	KLICK PIN - 7/16"	N/A
8	CS78712-5	BOLT - 7/8" NC. X 7 1/2" LG. GR. 5	N/A
9	LW78	LOCK WASHER - 7/8"	N/A
10	N78	NUT - 7/8"	N/A
11	W1062	PIVOT PLATE - TOP	30.3 LBS.
12	W1063	PIVOT PLATE - BOTTOM	32.6 LBS.
13	CS786-5	BOLT - 7/8" NC. X 6" LG. GR. 5	N/A
14	W1068	CLIP - CLAMP	1.5 LBS.
15	W1069	CLIP - CLAMP, WELDED	1.7 LBS.
16	W1120	BRACKET - FRONT	20.0 LBS.
17	CS582-5	BOLT - 5/8" NC. X 2" LG.	N/A
18	LW58	LOCK WASHER - 5/8"	N/A
19	N58	NUT - 5/8"	N/A
20	W1057	CROSS MEMBER - 5'3"	N/A
	W1058	CROSS MEMBER - 6'0"	N/A
	W1050	CROSS MEMBER - 6'9"	N/A
	W1060	CROSS MEMBER - 7' 6" TO 9' 9"	N/A
21	W1039	PIN - CROSS MEMBER	N/A

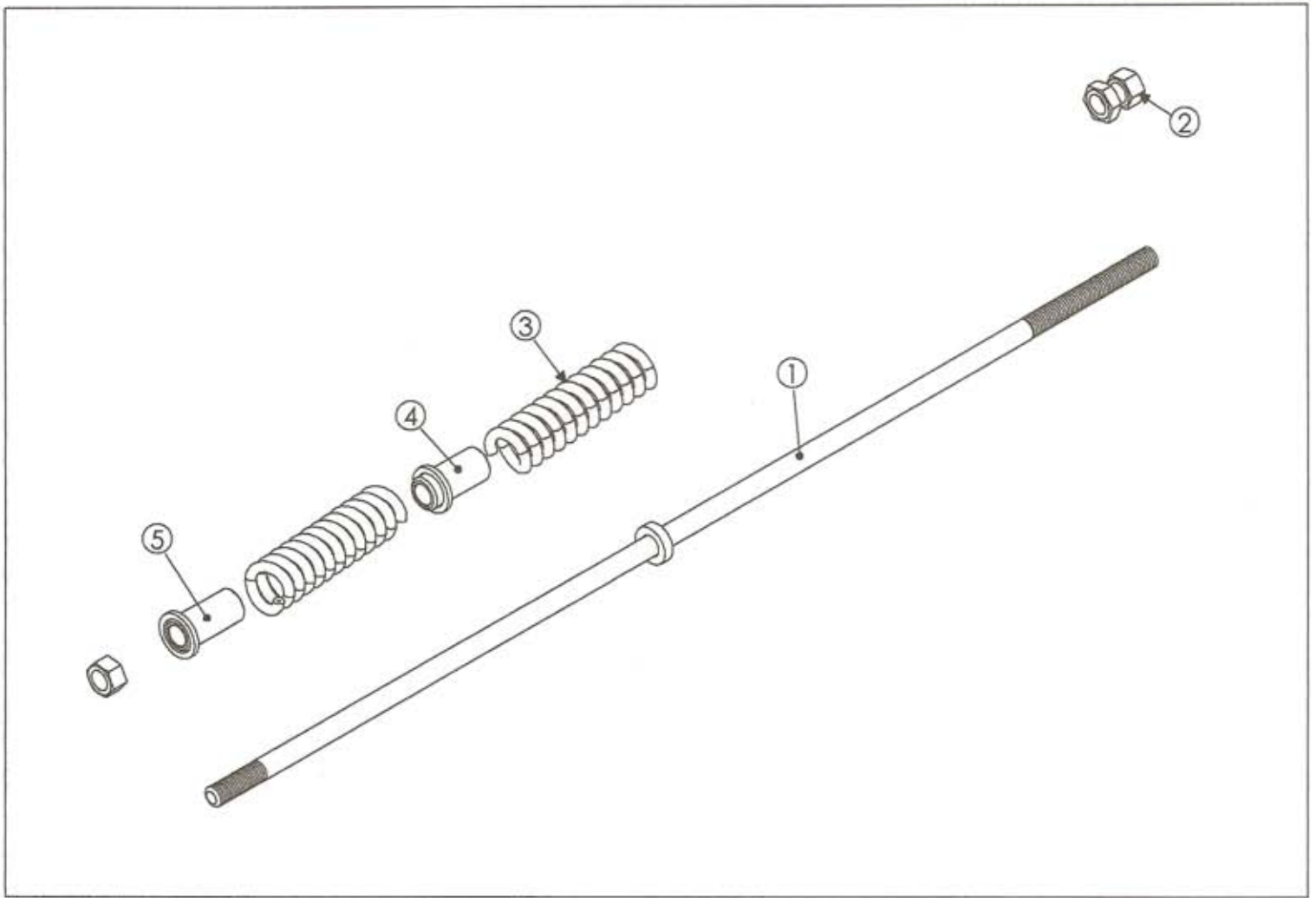

LEVELING ROD ASSEMBLY

REF. #	PART #	DESCRIPTION	APPROX. WT.
1	W1122	LEVELING ROD 5' 3" TO 9' 9"	13.0 LBS.
2	N1	NUT - 1" NC.	0.1 LBS.
3	W1124	SPRING	3.3 LBS.
4	W1133	COLLAR - SINGLE, SPRING	1.5 LBS.
5	W1134	COLLAR - DOUBLE, SPRING	1.5 LBS.

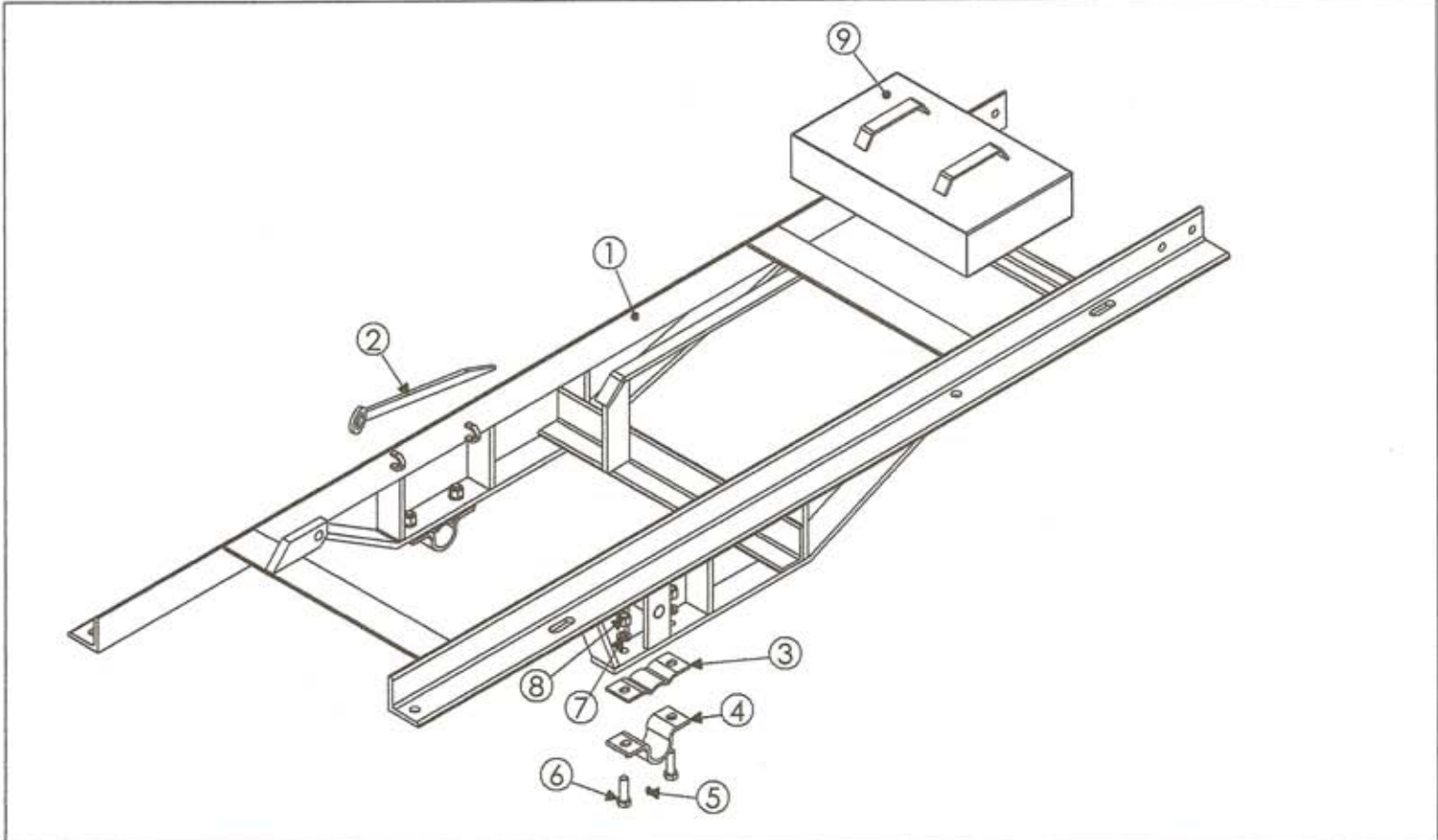

HWO-MAIN FRAME

REF. #	PART #	DESCRIPTION	APPROX. WT.
1	W1001	MAIN FRAME - 5' 3" TO 9' 9"	490.0 LBS.
2	W1011	WRENCH - 7/8" BOLT	2.6 LBS.
3	W1093	CLAMP - TOP (5' 3" TO 9' 9")	1.7 LBS.
4	W1095	CLAMP - BOTTOM (5' 3" TO 9' 9")	3.6 LBS.
5		GREASE KERK	N/A
6	CS34212-5	BOLT - 3/4" NC. X 2 1/2" LG.	N/A
7	LW34	LOCK WASHER - 3/4"	N/A
8	N34	NUT - 3/4"	N/A
9	W1007	WEIGHT BOX 5' 3" TO 9' 9"	150.0 LBS.

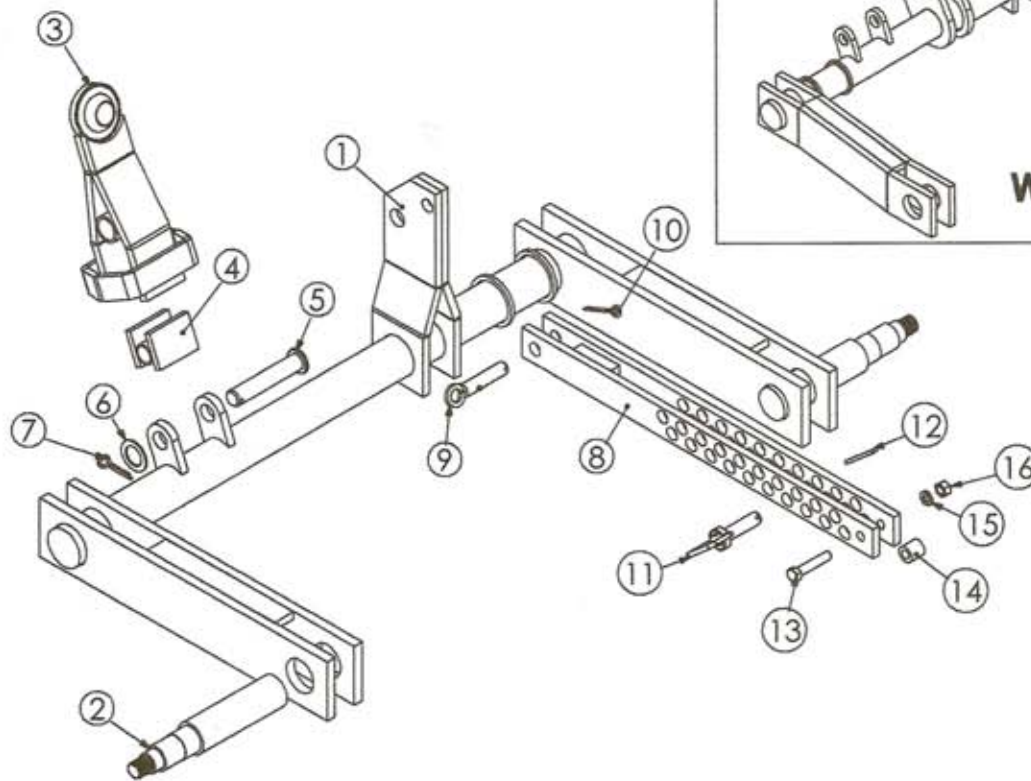

W1090-S

AXLE ASSEMBLY

REF. #	PART #	DESCRIPTION	APPROX. WT.
1	W1056	AXLE WELDMENT - SINGLE (5' 3")	202.0 LBS.
	W1090-S	AXLE ASSY. - ADJ., SPLIT TYPE	220.0 LBS.
2	DSH-312-W	SPINDLE	N/A
3	W1121	REAR BRACKET - 5' 3" TO 9' 9"	13.0 LBS.
4	W1107	BRACKET - ROCKER	1.9 LBS.
5	W1108	PIN - ROCKER (1" X 5")	N/A
6	FW114S	FLAT WASHER - 1 1/4" NOM, SAE.	N/A
7	CP14134	COTTER PIN - 1/4" X 1 3/4" LG.	N/A
8	W1098	BAR - DEPTH SET, 5' 3" TO 9' 9"	13.0 LBS.
9	W1101	PIN - ANCHOR, DEPTH SET BAR	N/A
10	CP3162	COTTER PIN - 3/16" X 2" LG.	N/A
11	W1100	PIN - DEPTH SET	N/A
12	HP6	COTTER -HAIR PIN TYPE #6	N/A
13	CS12212-5	BOLT - 1/2" NC. X 2 1/2" LG. GR.5	N/A
14	W1106	SPACER - DEPTH SET BAR	N/A
15	LW12	LOCK WASHER - 1/2"	N/A
16	N12	NUT - 1/2"	N/A

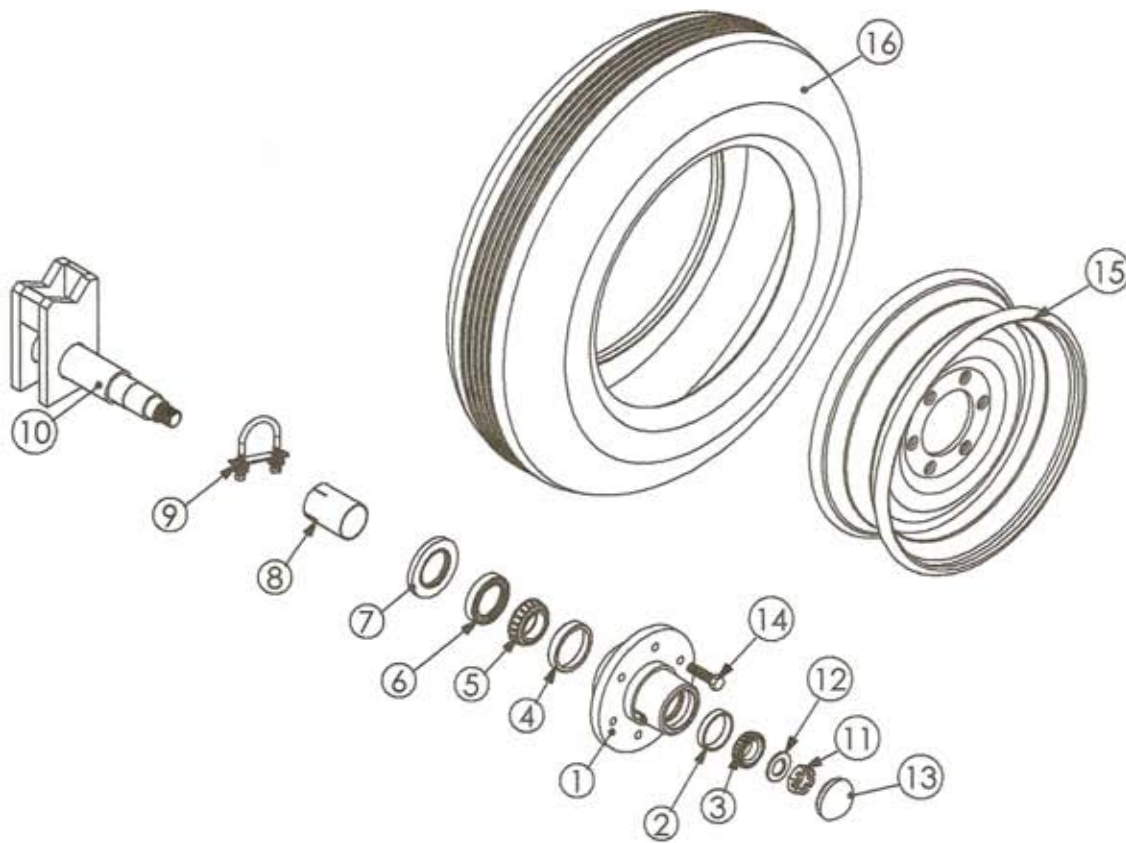

HWO-SPINDLE ASSEMBLY

REF#	PART #	DESCRIPTION	WT/LB.
1	DSH-302	HUB	10.0 LBS.
2	DSH-303	BEARING CUP, OUTER	0.1 LBS.
3	DSH-304	BEARING CONE, OUTER	0.3 LBS.
4	DSH-307	INNER SEAL	0.1 LBS.
5	DSH-305	BEARING CUP, INNER	0.2 LBS.
6	DSH-306	BEARING CONE, INNER	0.4 LBS.
7	DSH-308	OUTER SEAL	0.1 LBS.
8	DSH-309	TUBING SLEEVE	0.3 LBS.
9	DSH-310	CLAMP ASSY.	0.3 LBS.
10	DSH-312-W	WELD ON SPINDLE	9.0 LBS.
11	DSH-313	SLOTTED NUT	0.1 LBS.
12	DSH-314	SPINDLE WASHER	0.01 LBS.
13	DSH-316	DUST CAP	0.2 LBS.
14	DSH-318	LUG BOLT - (1/2" NF X 1" LG.)	0.1 LBS.
15	JJ-19	WHEEL-15 X 6, 6 (1/2)	23.0 LBS.
16	JJ-20	TIRE - 7.60-15, RIB 6 PLY	24.0 LBS.

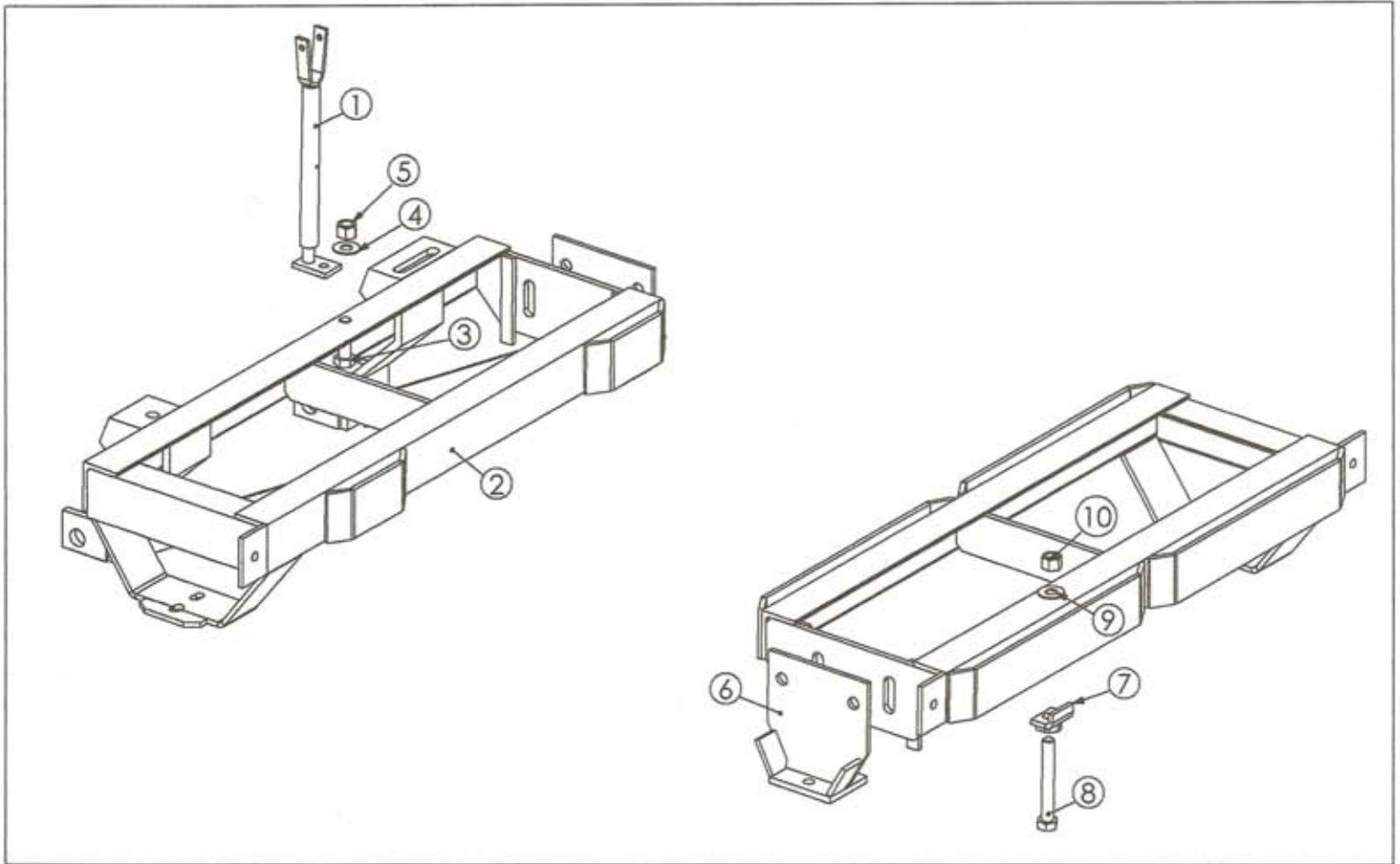

GANG FRAME ASSEMBLY

REF. #	PART #	DESCRIPTION	APPROX. WT.
1	W1005	HOSE GUIDE	3.0 LBS.
2	W1054	FRONT GANG FRAME - 5' 3"	170.0 LBS.
	W1055	FRONT GANG FRAME - 6' 0"	220.0 LBS.
	W1020	FRONT GANG FRAME - 6' 9"	270.0 LBS.
	W1021	FRONT GANG FRAME - 7' 6"	320.0 LBS.
	W1022	FRONT GANG FRAME - 8' 3"	370.0 LBS.
	W1023	FRONT GANG FRAME - 9' 0"	420.0 LBS.
	W1051	FRONT GANG FRAME - 9' 9"	470.0 LBS.
3	CS783-5	BOLT - 7/8" NC. X 3" LG.	N/A
4	W1029	FLAT WASHER - 7/8"	N/A
5	N78H	NUT - 7/8", HEAVY	N/A
6	W1026	BRG. BRACKET - BOLT ON (5' 3" ONLY)	12.7 LBS.
7	W1036	CLIP - FRAME CLAMP	0.9 LBS.
8	CS78612-5	BOLT - 7/8" NC. X 6 1/2" LG.	N/A
9	W1029	FLAT WASHER - 7/8"	N/A
10	N78H	NUT - 7/8", HEAVY	N/A
11	W1052	REAR GANG FRAME - 5' 3"	233.0 LBS.
	W1053	REAR GANG FRAME - 6' 0"	256.0 LBS.
	W1030	REAR GANG FRAME - 6' 9"	279.0 LBS.
	W1031	REAR GANG FRAME - 7' 6"	280.0 LBS.
	W1032	REAR GANG FRAME - 8' 3"	303.0 LBS.
	W1033	REAR GANG FRAME - 9' 0"	326.0 LBS.
	W1059	REAR GANG FRAME - 9' 9"	368.0 LBS.

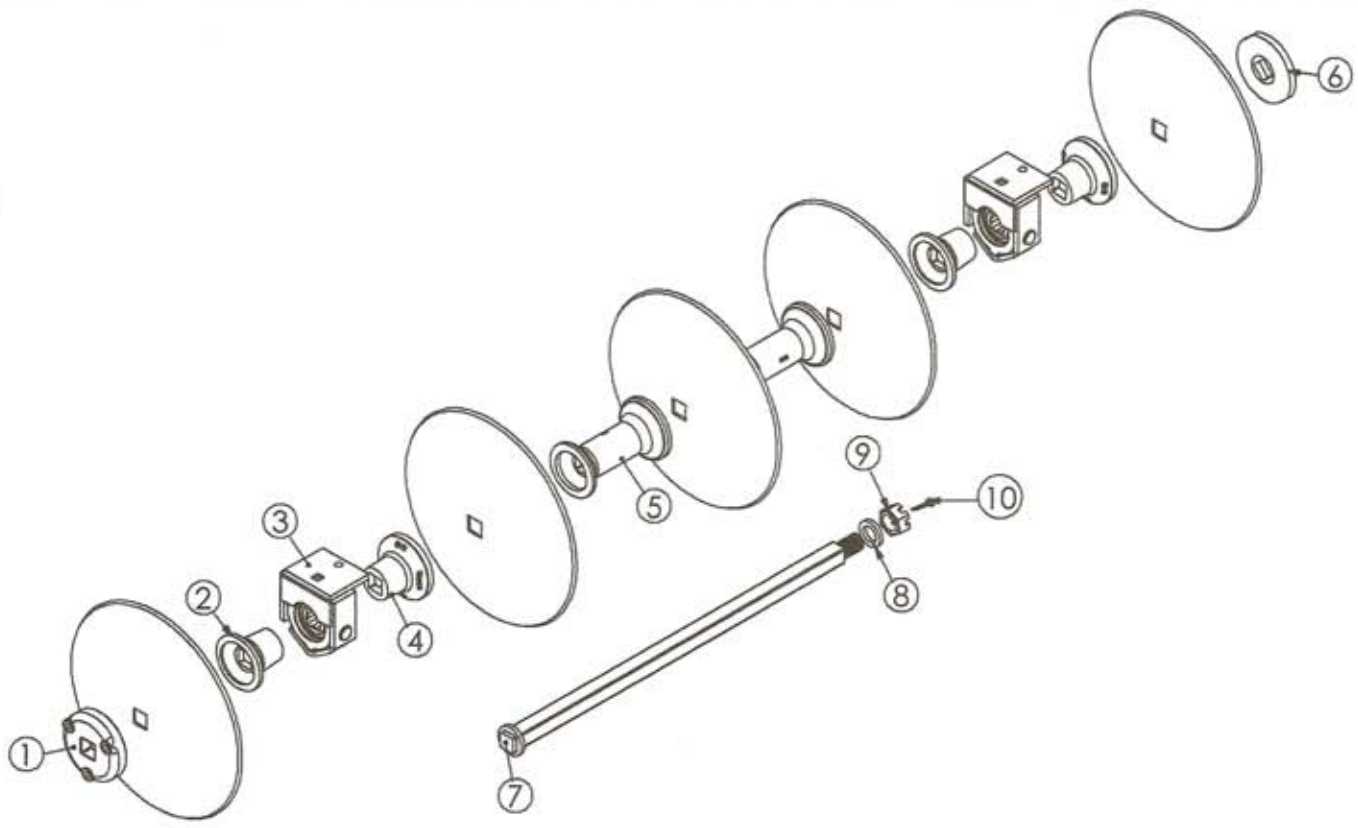

GANG ASSEMBLY

REF. #	PART #	DESCRIPTION	APPROX. WT.
1	JXE-19	EXT. WASHER -CCV., 1 1/2" SQ. (OUTSIDE OF BLADE)	N/A
	JXE-18	EXT. WASHER -CVX, 1 1/2" SQ. (INSIDE OF BLADE)	9.0 LBS.
2	XJ-84	HALF SPOOL - CVX 1 1/2" SQ.	N/A
3	X-80-A-KIT	BEARING ASSEMBLY - 1 1/2" SQ.	N/A
4	XJ-83	HALF SPOOL - CCV., 1 1/2"	N/A
5	X-90	SPACER SPOOL - 1 1/2" SQ., 9" SPACING	12.0 LBS.
6	X-98	STEEL WASHER - UNIVERSAL	N/A
7	XGR-5	GANG ROD - 5 BLADE, 1 1/2" SQ. 41 1/4" LG.	N/A
	XGR-6	GANG ROD - 6 BLADE, 1 1/2" SQ. 41 1/4" LG.	N/A
	XGR-7	GANG ROD - 7 BLADE, 1 1/2" SQ. 41 1/4" LG.	N/A
	XGR-7L	GANG ROD - 7L BLADE, 1 1/2" SQ. 41 1/4" LG.	N/A
	XGR-8L	GANG ROD - 8L BLADE, 1 1/2" SQ. 41 1/4" LG.	N/A
	XGR-9L	GANG ROD - 9L BLADE, 1 1/2" SQ. 41 1/4" LG.	N/A
8	LW112	LOCK WASHER - 1 1/2"	N/A
9	SN112	SLOTTED NUT - 1 1/2"	N/A
10	CP14212	COTTER PIN - 1/4" X 2 1/2" LG.	N/A

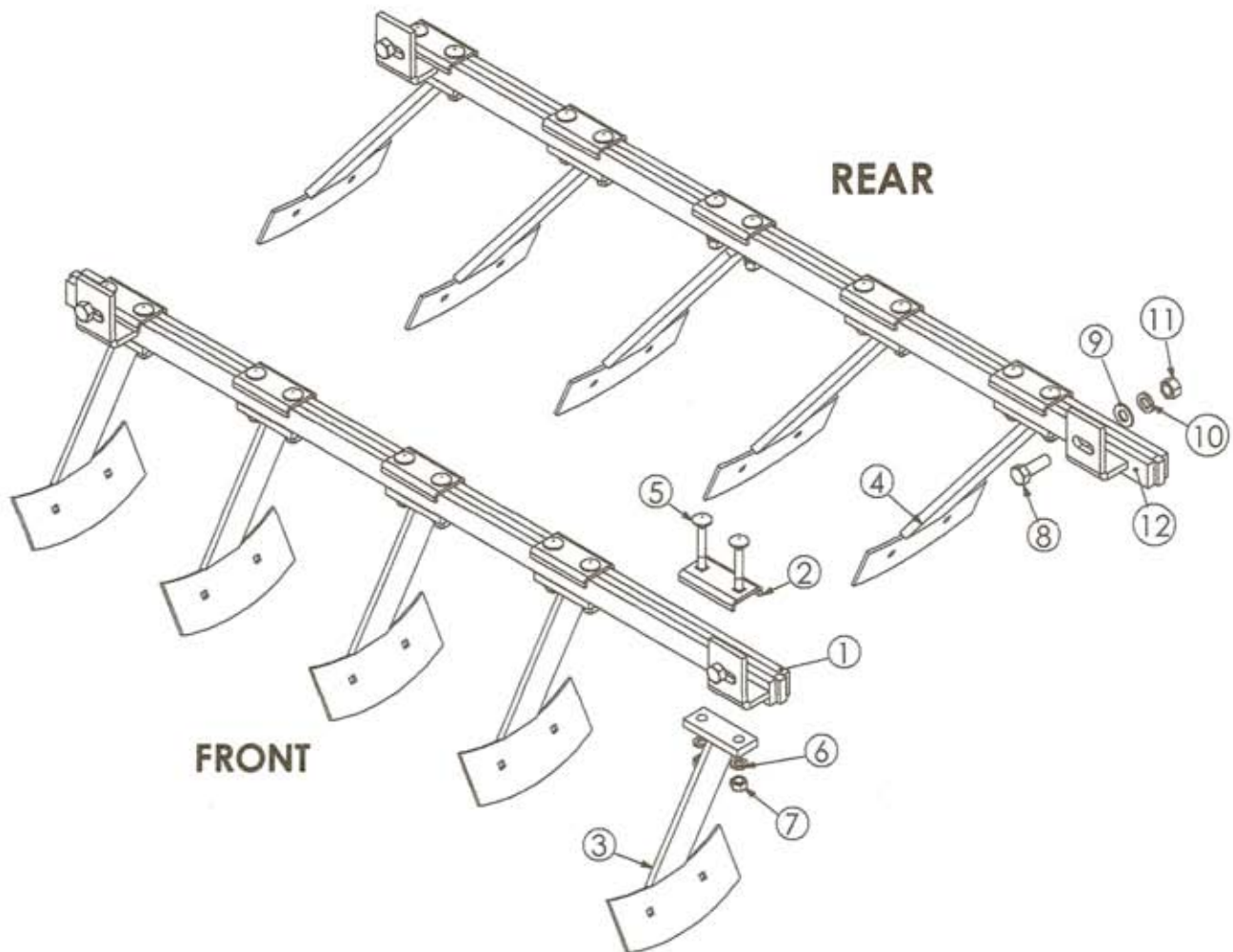

CLEANER ASSEMBLY

REF. #	PART #	DESCRIPTION	APPROX. WT.
1	WOC-53F	CLEANER BAR - FRONT 5' 3"	N/A
	WOC-60F	CLEANER BAR - FRONT 5' 3"	N/A
	WOC-69F	CLEANER BAR - FRONT 5' 3"	N/A
	WOC-76F	CLEANER BAR - FRONT 5' 3"	N/A
	WOC-83F	CLEANER BAR - FRONT 5' 3"	N/A
	WOC-90F	CLEANER BAR - FRONT 5' 3"	N/A
2	WOC-110	CLAMP - CLEANER ARM	N/A
3	WOC-111	CLEANER ARM - FRONT	N/A
4	WOC-112	CLEANER ARM - REAR	N/A
5	CB123-5	CARRIAGE BOLT - 1/2" NC. X 3" LG. GR. 5	N/A
6	LW12	LOCK WASHER - 1/2"	N/A
7	N12	NUT - 1/2"	N/A
8	CS58134-5	BOLT - 5/8" NC. X 1 3/4" LG. GR. 5	N/A
9	FW58	FLAT WASHER - 5/8"	N/A
10	LW58	LOCK WASHER - 5/8"	N/A
11	N58	NUT - 5/8"	N/A
12	WOC-53R	CLEANER BAR - REAR 5' 3"	N/A
	WOC-60R	CLEANER BAR - REAR 6' 0"	N/A
	WOC-76R	CLEANER BAR - REAR 7' 6"	N/A
	WOC-83R	CLEANER BAR - REAR 8' 3"	N/A
	WOC-90R	CLEANER BAR - REAR 9' 0"	N/A

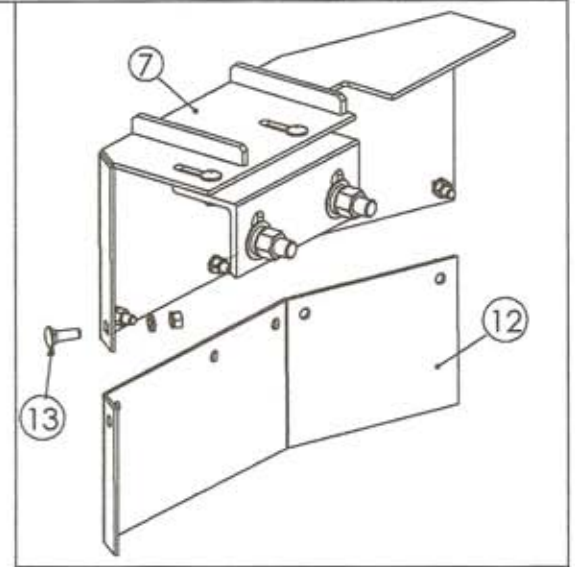
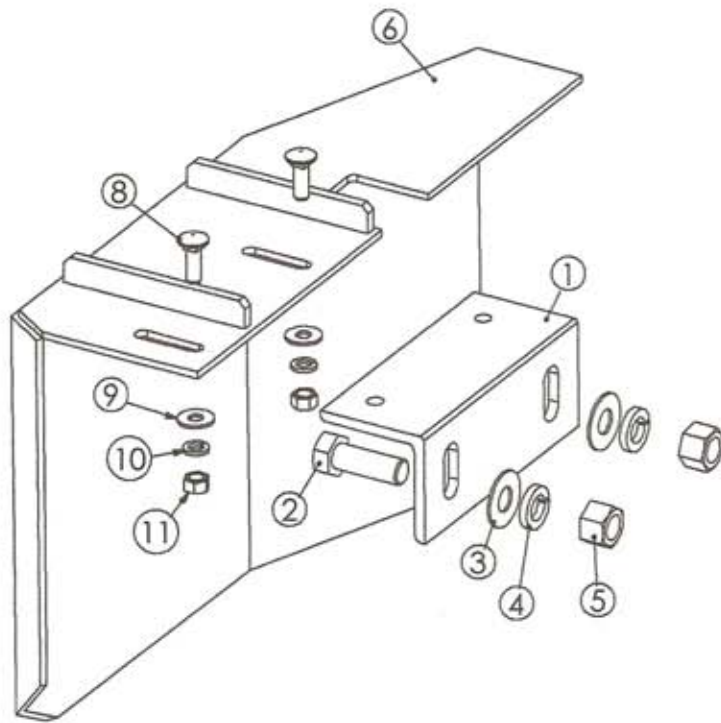

DIRT SHIELD ASSEMBLY

REF. #	PART #	DESCRIPTION	APPROX. WT.
1	W1132	ANGLE BRACKET DIRT SHIELD	N/A
2	CS78212-5	BOLT - 7/8" NC. X 2 1/2" LG.	N/A
3	FW78	FLAT WASHER - 7/8"	N/A
4	LW78	LOCK WASHER - 7/8"	N/A
5	N78	NUT - 7/8	N/A
6	W1130	DIRT SHIELD - RIGHT FRONT	N/A
	W1131	DIRT SHIELD - LEFT REAR	N/A
7	W1130-B	DIRT SHIELD - RIGHT FRONT, BELTED (OPTIONAL)	N/A
	W1131-B	DIRT SHIELD - LEFT REAR, BELTED (OPTIONAL)	N/A
8	CB12112-5	CARRIAGE BOLT - 1/2" X 1 1/2" LG.	N/A
9	FW12	FLAT WASHER - 1/2"	N/A
10	LW12	LOCK WASHER - 1/2"	N/A
11	N12	NUT - 1/2"	N/A
12	W-RB	RUBBER BELT - BELTED DIRT SHIELDS	N/A
13	CB12112-5	CARRIAGE BOLT - 1/2" X 1 1/2" LG.	N/A

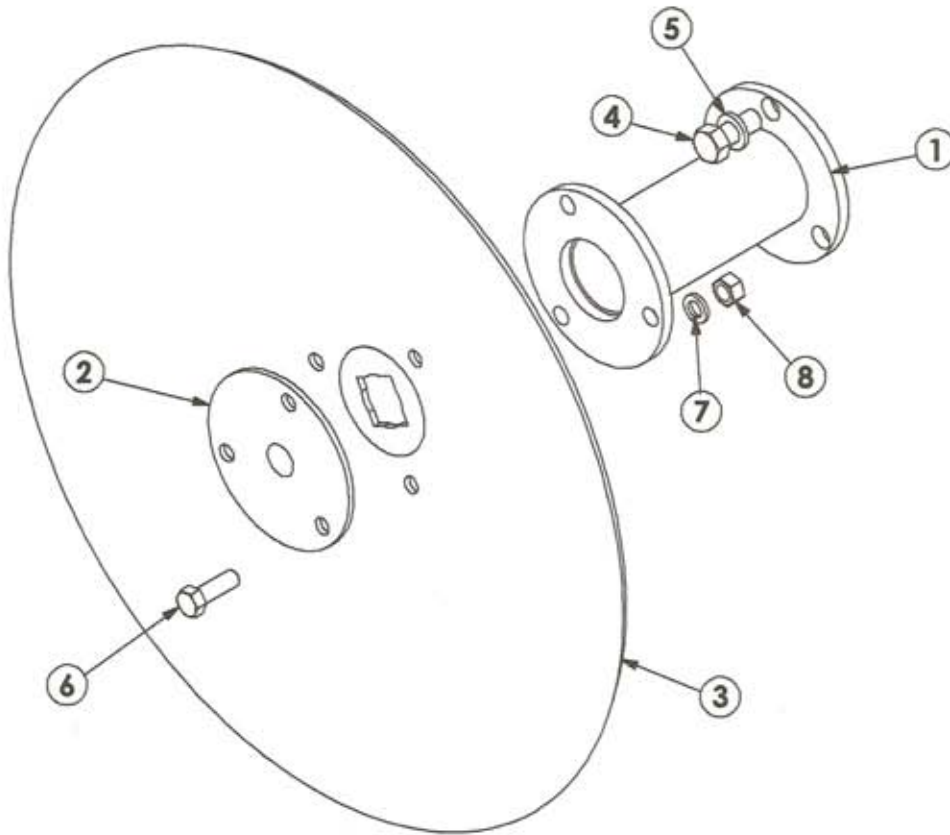

EXTENSION SPOOL ASSEMBLY

REF#	PART #	DESCRIPTION	WT/LB.
1	JXE-16	EXT. SPOOL - (BLADE THROWS OUT) 9"	12.0 LBS.
	JXE-17	EXT. SPOOL - (BLADE PULL IN) 9"	2.0 LBS.
2	JXE-20	END CAP - UNIVERSAL	0.2 LBS.
3	DISC BLADE	BLADE SIZE ON DISC	2.0 LBS.
4	CS58134-5	BOLT - 5/8" NC. X 1 3/4" LG. GR - 5	5.8 LBS.
5	LW58	LOCK WASHER - 5/8"	N/A
6	CS12112-5	BOLT - 1/2" NC. X 1 1/2" LG. GR - 5	N/A
7	LW12	LOCK WASHER - 1/4"	N/A
8	N12	NUT - 1/2"	N/A

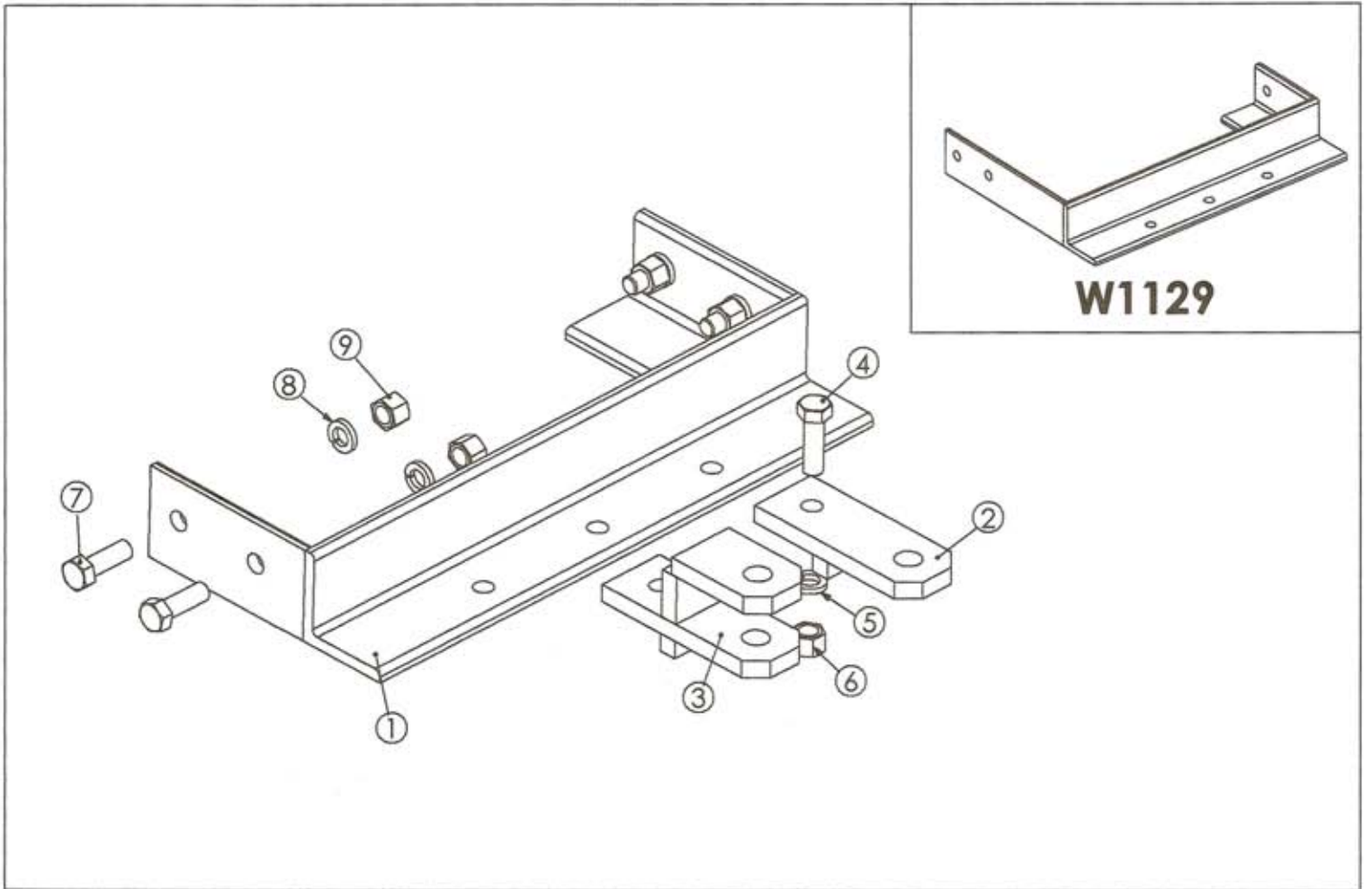

TOW HITCH ASSEMBLY

REF. #	PART #	DESCRIPTION	APPROX. WT.
1	W1129-S	TOW HITCH FRAME - STANDARD (MADE AFTER 12/07)	18.0 LBS.
	W1129	TOW HITCH FRAME - OLD STYLE	18.0 LBS.
2	W1127	TONGUE SINGLE LIP	5.2 LBS.
3	W1128	TONGUE CLEVIS	N/A
4	CS34212-5	BOLT - 3/4" NC. X 2 1/2" LG. GR. 5	N/A
5	LW34	LOCK WASHER - 3/4"	N/A
6	N34	NUT - 3/4"	N/A
7	CS34214-5	BOLT - 3/4" NC. X 2 1/4" LG. GR. 5	N/A
8	LW34	LOCK WASHER - 3/4"	N/A
9	N34	NUT - 3/4"	N/A